

新北基高級中等學校

112 學年度學科能力測驗聯合模擬考試

英文考科

請於考試開始鈴響起，在答題卷簽名欄位以正楷簽全名

—作答注意事項—

考試範圍：第 1~3 冊

考試時間：100 分鐘

作答方式：

- 選擇題用 2B 鉛筆在「答題卷」上作答；更正時，應以橡皮擦擦拭，切勿使用修正液（帶）。
- 非選擇題用筆尖較粗之黑色墨水的筆在「答題卷」上作答；更正時，可以使用修正液（帶）。
- 考生須依上述規定畫記或作答，若未依規定而導致答案難以辨識或評閱時，恐將影響考生成績並傷及權益。
- 答題卷每人一張，不得要求增補。

選擇題計分方式：

- 單選題：每題有 n 個選項，其中只有一個是正確或最適當的選項。各題答對者，得該題的分數；答錯、未作答或畫記多於一個選項者，該題以零分計算。
- 多選題：每題有 n 個選項，其中至少有一個是正確的選項。各題之選項獨立判定，所有選項均答對者，得該題全部的分數；答錯 k 個選項者，得該題 $\frac{n-2k}{n}$ 的分數；但得分低於零分或所有選項均未作答者，該題以零分計算。

祝考試順利



版權所有·翻印必究

第壹部分、選擇題（占 62 分）

一、詞彙題（占 10 分）

說明：第 1. 題至第 10. 題為單選題，每題 1 分。

1. I felt instant _____ as soon as I handed in my report. Now I can finally get a good night's sleep.
(A) breath (B) sense (C) relief (D) quality
2. There is only _____ difference between the two designs. In fact, most people have trouble telling them apart.
(A) excess (B) plain (C) slight (D) proper
3. With plenty of work left to do, Mark _____ put off a reunion dinner with his high school classmates to a later date.
(A) additionally (B) generally (C) respectively (D) reluctantly
4. Making rude or offensive _____ on the Internet is likely to get you into legal trouble these days.
(A) punches (B) approvals (C) remarks (D) portions
5. The company did a lot of surveys to better _____ their target customers, that is, to know who is more likely to buy their products.
(A) define (B) contain (C) launch (D) promote
6. Even after decades, I still have _____ memories of the day I graduated from high school as if it were yesterday.
(A) bright (B) normal (C) present (D) vivid
7. By means of repetition and exaggerated gestures, Judy _____ how we could improve sales during her short speech.
(A) highlighted (B) intended (C) imported (D) sustained
8. We didn't expect him to come up with the solution in such a short time, but now his _____ has impressed all of us.
(A) brilliance (B) obstacle (C) persuasion (D) substance
9. He became quite _____ after I turned down his invitation, and we hardly talk these days.
(A) guilty (B) distant (C) practical (D) optimistic
10. Workers _____ the heavy machinery are reminded not to drink alcohol or take medication that may make them drowsy before work.
(A) operating (B) founding (C) proposing (D) reserving

二、綜合測驗（占 10 分）

說明：第 11. 題至第 20. 題為單選題，每題 1 分。

第11.至15.題為題組

Seen throughout the city, manholes are the circular or rectangular metal-covered openings on the side of roads. They provide 11. underground utility system, such as sewers, storm drains, or utility lines. They are indispensable because they allow workers to enter the underground spaces and perform tasks such as cleaning, repairs, and installations. 12. of manholes will cause safety hazards like flooding or cases where pedestrians or vehicles fall into manholes.

In Japan, a unique mobile game has emerged, aiming to meet infrastructure needs by encouraging people to discover and report damaged manholes. The game gets players to 13., identify damaged manholes, and report their locations using their smartphones. This approach encourages public participation in civic matters, and 14. aids the authorities in prioritizing repairs.

Though the idea sounds promising, the game developer and the government have yet to resolve problems that may arise, like the risk of misinformation and 15. areas with little to no player participation. Care must be taken to deal with these challenges so that we can ensure safety for all road users.

11. (A) access to (B) tendency for (C) emphasis on (D) functions of
 12. (A) Critical thinking (B) Widespread coverage (C) Multiple purposes (D) Poor maintenance
 13. (A) examine their life closely (B) deepen their knowledge
 (C) expand social circles (D) explore their surroundings
 14. (A) by contrast (B) in turn (C) for instance (D) at most
 15. (A) arousing (B) enhancing (C) neglecting (D) recovering

第16.至20.題為題組

It's widely known that bees are important for our ecosystem and that they are facing increasing threats from modern agricultural practices involving pesticides. What many of us don't know, 16., is that some industries should shoulder a bigger share of blame than they're given.

The almond industry, for instance, has quite an adverse impact on bee colonies. One potential harm to bee colonies is the stress caused by transporting them over long distances to almond orchards for the task of pollination. This transportation can be stressful for the bees, hence 17. them more vulnerable to diseases and pests. Moreover, since they're 18., having limited food sources aside from almond flowers further weakens bee colonies. Still another problem is the 19. of honeybees to pesticides and other chemicals used in almond production.

One sustainable solution is to make habitats and species within almond orchards more 20. and stable. By creating various ecosystems and introducing other insects among almond trees, at least we can ensure enough food supply for bees and even lower the use of pesticides for almond trees in the long run.

16. (A) therefore (B) however (C) in addition (D) for a start
 17. (A) make (B) made (C) making (D) to make
 18. (A) faced with a great increase in demand (B) raised in their natural environment
 (C) looked after by beekeepers carefully (D) physically removed from their habitat
 19. (A) cultivation (B) delivery (C) exposure (D) restriction
 20. (A) worthy (B) diverse (C) pleasant (D) particular

三、文意選填（占 10 分）

說明：第21.題至第30.題為單選題，每題 1 分。

第21.至30.題為題組

Hospice care refers to a specialized and compassionate form of medical attention and support provided to people with terminal illnesses and their family or caregivers.

Patients on hospice care benefit from more 21. attention and services tailored to their needs. A dedicated team will attend to every patient in person, taking into account his or her personal preferences as well as medical history. Patients are usually offered effective management of 22. such as pain to ensure optimal comfort and well-being, and help with activities of daily living. Beyond the physical aspects, hospice care 23. spiritual support to patients while looking after their mental health. Skilled professionals provide one-on-one talks or counseling to help patients 24. the emotional challenges associated with end-of-life experiences.

Families and caregivers also receive invaluable support and education. Respite options, for example, allow caregivers to take much-needed breaks lest they should be 25. and worn out. Subsequent services also assist them in coping with 26. after the patient's passing or death. In a word, families of patients on hospice care can take comfort in the 27. shown to them by the caring medical staff and social workers throughout the process.

Some, however, have problems with this concept due to cultural and religious beliefs. They may raise 28. regarding hastening death, or fear inadequate pain management. They may instead 29. more aggressive medical options or prefer to prolong life at any cost. Others are worried whether the care helps preserve patients' 30. or self-esteem once they become hardly able to bathe or feed themselves. Whatever issues people may have, there's no denying that hospice care is important, for both patients and their family, and is thus here to stay.

- | | | | | |
|--------------|-----------------|-------------|-------------|----------------|
| (A) concerns | (B) overwhelmed | (C) favor | (D) empathy | (E) individual |
| (F) extends | (G) symptoms | (H) address | (I) grief | (J) dignity |

四、篇章結構（占 8 分）

說明：第31.題至第34.題為單選題，每題 2 分。

第31.至34.題為題組

While gaining Michelin recognition can be a significant achievement for a cook or a restaurant, it's important to consider the downsides that come with it. One major disadvantage is the financial burden. Sticking to the standards required for Michelin stars carries a high price tag. 31. These additional costs can eat into the potential financial benefits that a Michelin honor might bring.

Another downside is the uncertain impact on profitability. While Michelin stars are considered superb honors within the industry, average consumers may not prioritize them when choosing a restaurant. 32. In fact, the higher prices typically associated with Michelin-starred establishments can discourage some potential customers who are unable or unwilling to pay the premium.

Also, we cannot overlook the increased pressure and limited creative freedom for restaurant workers. After all, Michelin stars bring higher expectations from both diners and the culinary community. 33. This can be especially worrying to restaurant owners who want to keep their experienced and qualified employees for as long as they can.

34. The costs of maintaining the required standards and the varying consumer preferences can impact how much Michelin-starred establishments will earn. Restaurants should carefully evaluate the costs before pursuing or retaining Michelin recognition.

- (A) From using top-quality ingredients to hiring skilled staff, the expenses can quickly add up.
- (B) Restaurant owners are thus advised to think it over before setting their sights on Michelin recognition.
- (C) For customers, there are more decisive factors such as locations, prices, and personal preferences.
- (D) To consistently deliver exceptional dining experiences can be demanding for chefs and restaurant staff.

五、閱讀測驗（占 24 分）

說明：第35.題至第46.題為單選題，每題 2 分。

第35.至38.題為題組

The yeti crab is a fascinating deep-sea creature that lives in the depths of the ocean. The yeti crab has a distinctive appearance that sets it apart from other creatures. Its most striking feature is the dense and thick covering of hair-like bristles on its body, which is an oval-shaped exoskeleton that is pale or whitish in color. The crab's large and hairy claws help it capture tiny organisms and particles from the water. Its legs, in comparison, are believed to have shrunk greatly through evolution. Also, it has small eyes on long and thin stalks to sense its challenging environment with extremely high pressure, darkness, and high temperatures.

Yeti crabs play a crucial role in the deep-sea ecosystem. Unlike large marine animals like sharks and whales, yeti crabs are primary scavengers, relying on their claws to comb through the ocean floor in search of scraps and decaying organic matter. By consuming and recycling the remains of dead animals or plants, yeti crabs help prevent the spread of diseases and clean up the environment. Furthermore, a yeti crab also serves as a host for special bacteria among its hairy bristles, forming a **symbiotic** relationship. That is, these bacteria derive energy and nutrients from chemical compounds in the crab's habitats, while the crab benefits from the organic molecules produced by the bacteria.

Despite its remarkable adaptations, the yeti crab faces several threats in its deep-sea habitat. One significant issue has to do with deep-sea mining activities. With increasing interest in mining for minerals and resources in the deep sea, the delicate ecosystems where yeti crabs reside are at risk of destruction and disturbance. Climate change also poses a threat. The yeti crab's reliance on specific conditions makes it especially vulnerable to any disruptions in these ecosystems. Currently, efforts are underway to conserve the threatened yeti crabs, including closer monitoring and implementing sustainable fishing practices. Time will tell whether those efforts will pay off in the long run.

35. Which of the following pictures is most likely a yeti crab?

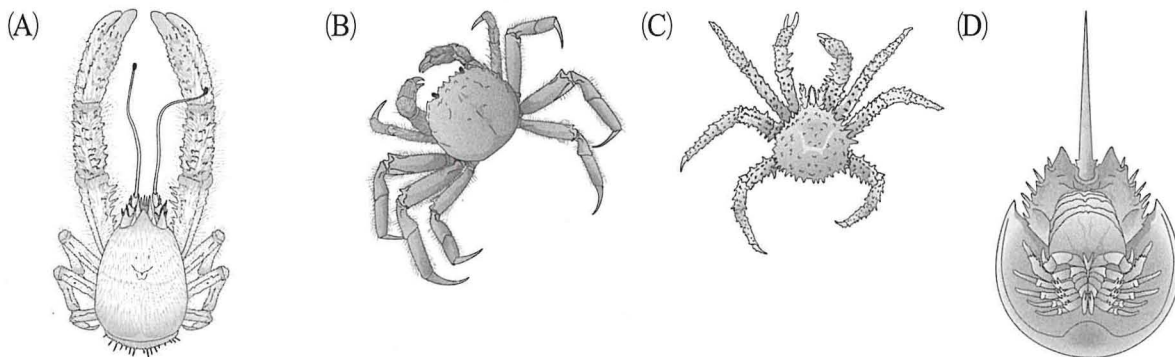

36. Which of the following is true according to the passage?

- (A) Yeti crabs are at the top of the marine food chain.
- (B) Yeti crabs live in a hostile or harsh environment.
- (C) Yeti crabs are known to feed on much larger fish.
- (D) Yeti crabs are close to becoming extinct these days.

37. Which of the following relationships can be described as “**symbiotic**,” as in the second paragraph?

- (A) Animals help each other survive by providing each other with necessary conditions.
- (B) Animals develop special organs in order to get used to their environment.
- (C) Animals are dying fast because of a lack of food in their natural habitats.
- (D) Animals change their skin color based on their immediate surroundings.

38. What is the main idea of the last paragraph?

- (A) Several efforts are made to ensure the survival of yeti crabs.
- (B) Human activities have a negative impact on yeti crabs.
- (C) Yeti crabs are increasingly sensitive to changes in their environment.
- (D) Both natural and man-made challenges threaten yeti crabs.

第39.至42.題為題組

The puzzle of the Tower of Hanoi can be traced back to an ancient temple in Benares, India. Legend has it that inside the temple stood a tower of neatly-stacked gold disks, and the monks were assigned the extraordinary task of moving the entire tower of disks to the opposite end of the temple, where another tower without any disks lay.

The rules of the Tower of Hanoi puzzle are straightforward yet restrictive. Firstly, only one disk can be moved at a time. Secondly, a disk can only be placed on top of a larger disk or an empty stick, banning the placement of a larger disk on top of a smaller one. The puzzle is solved when all the disks are moved onto the last stick, with all the disks placed in the same order of sizes. The challenge here is to finish the puzzle with as few steps as possible.

Days turned into weeks, and weeks into months as the monks struggled with the puzzle. Their hope began to wane until a young boy appeared, offering to solve the puzzle. With focus and remarkable skill, he worked the disks while following the rules with utmost precision. As the final disk found its place, rays of light devoured the temple, meaning the completion of the task as well as the end of the world.

The Tower of Hanoi puzzle gained international attention in the 19th century when it was introduced to the Western world by the French mathematician Edouard Lucas. Lucas, known for his interest in recreational mathematics, popularized the puzzle. Later on, the puzzle found applications in mathematics, computer science, problem-solving, and education. Supposed to strengthen critical thinking, spatial awareness, and logical reasoning, the puzzle is now extensively used for recreational and educational purposes. Holding great appeal and boasting a long history, the Tower of Hanoi is surely more than just an intriguing puzzle for people.

39. What is the best title of this passage?

- (A)“The Tower of Hanoi, a historic landmark.”
- (B)“A versatile intellectual challenge.”
- (C)“How math can help raise our quality of life.”
- (D)“Legendary figures in mathematics.”

40. Which of the following is **NOT** true about the Tower of Hanoi puzzle according to the passage?

- (A) It involves moving disks of different sizes between sticks.
- (B) It has historical ties with the city of Hanoi, Vietnam.
- (C) It wasn't meant as a tool for teaching math initially.
- (D) Its popularity can be attributed to a French scholar.

41. Which of the following is mentioned in the passage?

- (A) Why monks attempted to solve the Tower of Hanoi.
- (B) Why solving the puzzle meant the end of the world.
- (C) How the puzzle has developed in the last few centuries.
- (D) How to solve the puzzle with as few steps as possible.

42. Which of the following is the correct set of steps in playing the puzzle?

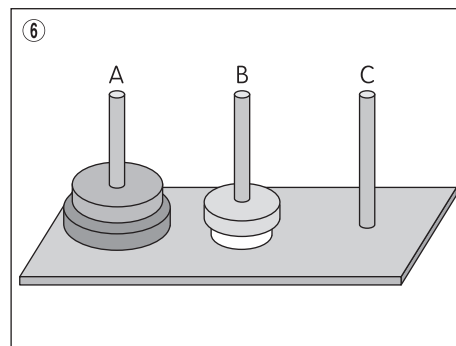
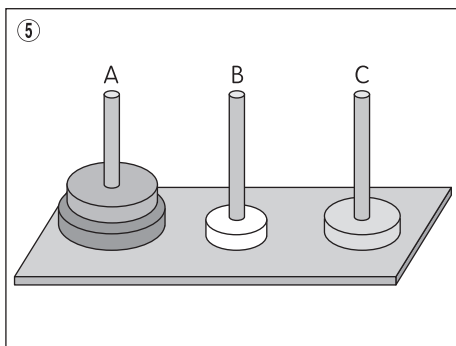
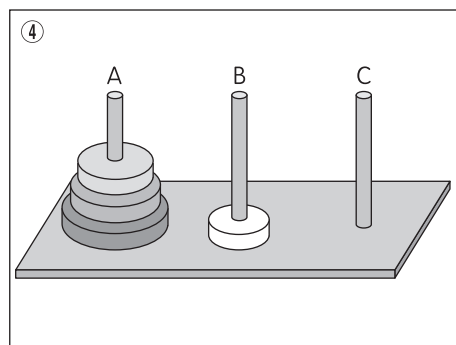
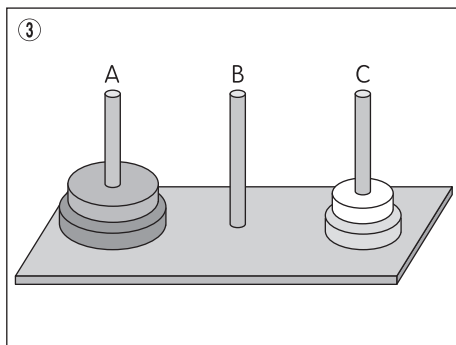
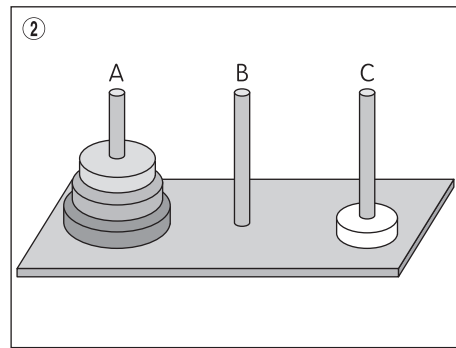
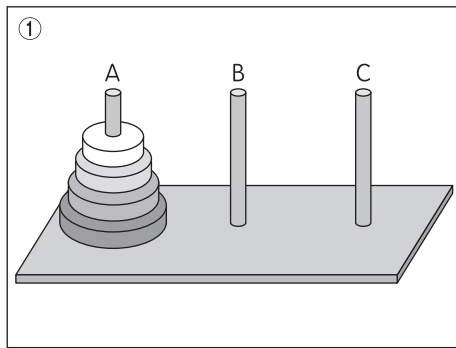

- (A) Step 1: ① Step2: ② Step 3: ④ Step 4: ⑥
- (B) Step 1: ① Step2: ③ Step 3: ④ Step 4: ⑤
- (C) Step 1: ① Step2: ③ Step 3: ② Step 4: ⑤
- (D) Step 1: ① Step2: ④ Step 3: ⑤ Step 4: ③

第43.至46.題為題組

As a social phenomenon, cancel culture centers around holding individuals or groups responsible for their actions or statements with open criticism and withdrawal of support. The roots of cancel culture can be traced back to the early 2010s when social media platforms provided a means for **marginalized** voices to be heard. Under such culture, those who were once silenced, ignored, or deprived of their rights feel encouraged to come forward to expose and challenge the behavior of certain public figures who have engaged in discriminatory or offensive acts.

One incident involving Kevin Hart, an American comedian, is an example of cancel culture. Old homophobic tweets came to light when he was announced as the Oscars host, leading to harsh criticism and demands for his removal. Hart initially refused to apologize but eventually stepped down due to pressure. The case sparked a debate on humor, accountability, and social media's influence. It shows how cancel culture can quickly affect public figures while prompting the public to think about fairness and social media's role.

These days, opinions seem divided about cancel culture. Some argue that cancel culture serves as an essential tool to bring people to justice for their wrongdoing. They believe it promotes social progress and encourages a safer and more inclusive society. Others argue that cancel culture harms free speech and creates an atmosphere of fear and self-censorship. In their opinion, cancel culture now involves bringing up what people did or said in the past, oftentimes without considering the full context. They contend that it often operates based on incomplete evidence or information, and mob mentality, leading to unfair consequences for individuals. Whichever side one takes on cancel culture, no one can deny that in this world of interconnectivity, we must be careful with our actions and words.

43. What does it mean when someone is “**marginalized**”?
- (A) Someone is treated as if he or she weren't important.
 - (B) Someone is considered a troublemaker in a group.
 - (C) Someone is attracting a lot of unwanted attention.
 - (D) Someone is criticized for his or her past mistakes.
44. Which of the following situations is a typical case of cancel culture at play?
- (A) Celebrities made a fortune by criticizing the authorities in their weekly videos.
 - (B) A food vendor became well-known for his secret acts of generosity over the years.
 - (C) A politician was forced to quit his job when his criminal offense was publicized online.
 - (D) Low-achieving students were bullied in their class chat group by their classmates.
45. Which of the following is **NOT** mentioned in the passage?
- (A) The definition of cancel culture.
 - (B) The origin of cancel culture.
 - (C) Different views on cancel culture.
 - (D) Author's own criticism of cancel culture.
46. What can be inferred from the last paragraph of this passage?
- (A) The government has a crucial role to play in encouraging cancel culture.
 - (B) Some may suffer unjustly or unnecessarily because of cancel culture.
 - (C) One's past records seem to matter little in cancel culture.
 - (D) The public always take sides with those who seem mistreated.

第貳部分、混合題（占 10 分）

說明：本部分共有 1 題組，每一子題配分標於題末。限在答題卷標示題號的作答區內作答，並依規定用筆作答。

第47.至50.題為題組

These days, it's not hard to find charities placing advertisements or making commercials in both traditional media outlets and social media platforms. People can't help but wonder whether that's an appropriate or necessary approach, hence a heated discussion on the issue. Below are views expressed by different people.

- (A) Lin: "Advertising is a game-changer! Never before have we seen a more effective tool in getting people to donate or part with their loose change. Through TV, newspapers, and social media, charities can reach massive audiences, stir emotions, and rally support. Last year we raised over 10 million dollars on Facebook alone, and we're looking to expand our advertising campaigns this year."
- (B) Santos: "Charities should conduct thorough research and analysis to determine if advertising meets their goals and engages their target audience. It's essential to examine the potential benefits and costs to make informed decisions that maximize the impact of their efforts."
- (C) Judy: "Let's consider the financial reality. While advertising has its advantages, we can't dismiss the significant costs involved. Charities, often working with limited budgets, must weigh the trade-off between advertising and direct assistance."
- (D) Jane: "Picture this: convincing storytelling and captivating visuals that spark feelings. By conveying urgency and significance and probably moving the audience to tears with first-hand accounts and personal stories that strike a chord with the public, charities create deep connections, and nurture a devoted support base committed to making a lasting difference."
- (E) Joon: "While advertising has its place, nothing compares to personal connections. Charities should prioritize face-to-face engagement, enabling people to experience their work firsthand and fostering unbreakable bonds of trust and support."

47. Which word from the opinions above means "someone or something that turns a situation around dramatically, often in a positive and desirable way"? (簡答，2 分)

48. -49. Please fill in the following blanks with the name of interviewees according to their views above. (填充，4 分)

48. _____ is most likely to suggest that charities hold events where potential donors meet in person with those who may benefit, such as the disadvantaged.

49. _____ is most likely to suggest hiring a director to produce short films that can connect with the audience on the emotional level as advertisement materials.

50. Please choose the correct statements according to the interview results above. (多選題，4 分)

- (A) At least one interviewee expressed his or her worry that shooting commercials may be unaffordable or impractical for a charity.
- (B) One interviewee is convinced that the trend in question will certainly die down in the near future.
- (C) It was pointed out that there's a need for the government to pass related regulations on charities placing advertisements.
- (D) None of the interviewees cited his or her past failures as an argument against employing advertisements to increase donations.
- (E) All of the interviewees used to work, or are currently employed in a charitable organization.

第參部分、非選擇題（占 28 分）

說明：本部分共有二大題，請依各題指示作答。答案必須寫在「答題卷」標示題號之作答區內，作答時不必抄題。

一、中譯英（占 8 分）

說明：依題號將以下中文句子譯成正確、通順、達意的英文。每題 4 分，共 8 分。

1. 我的同事是一位愛冒險的遊客，常常造訪大部分臺灣人不熟的國家。
2. 儘管有潛在的風險，到那些地方旅遊可以滿足他的好奇心，並豐富他的生活。

二、英文作文（占 20 分）

說明：依提示寫一篇英文作文，文長至少 120 個單詞（words）。

提示：許多高中都會在學期間舉辦園遊會（school fair），用來慶祝校慶（school anniversary）或是其他特殊節日。圖片是某高中的園遊會場景，請同學寫一篇兩段的文章，第一段描述圖片當中發生的事情，第二段請就你自己或是他人的經驗，討論你認為高中是否應該舉辦園遊會，並且詳述原因。

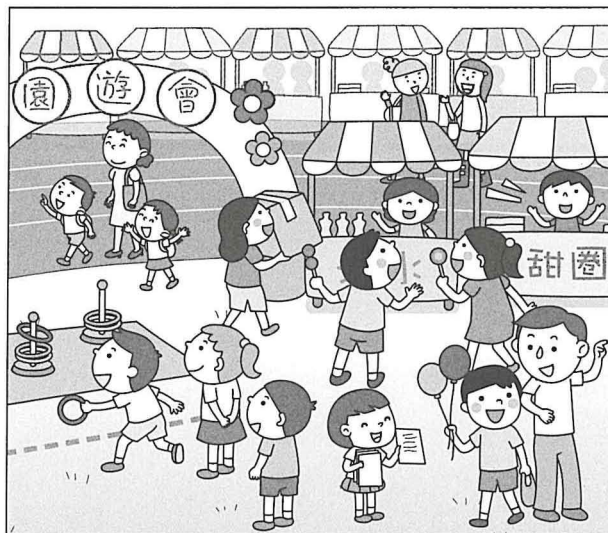

新北基高級中等學校

112 學年度學科能力測驗聯合模擬考試

英文
考科
參考
答案
暨
詳
解

翰林出版事業股份有限公司



版權所有・翻印必究

英文考科詳解

1.	2.	3.	4.	5.	6.	7.	8.	9.	10.
(C)	(C)	(D)	(C)	(A)	(D)	(A)	(A)	(B)	(A)
11.	12.	13.	14.	15.	16.	17.	18.	19.	20.
(A)	(D)	(D)	(B)	(C)	(B)	(C)	(D)	(C)	(B)
21.	22.	23.	24.	25.	26.	27.	28.	29.	30.
(E)	(G)	(F)	(H)	(B)	(I)	(D)	(A)	(C)	(J)
31.	32.	33.	34.	35.	36.	37.	38.	39.	40.
(A)	(C)	(D)	(B)	(A)	(B)	(A)	(D)	(B)	(B)
41.	42.	43.	44.	45.	46.	47.	48.	49.	50.
(C)	(D)	(A)	(C)	(D)	(B)	見詳解	見詳解	見詳解	見詳解

第壹部分、選擇題

一、詞彙題

目標：評量考生對高中常用實詞詞彙 (content words) 的構詞、語意、字詞搭配 (collocation) 的理解與運用能力。

- (C) 難易度：中
解析：我一交完報告就感到瞬間解脫。現在我終於可以睡個好覺了。
(A)呼吸 (B)感受 (C)輕鬆；解脫 (D)品質
- (C) 難易度：中
解析：這兩個設計之間只有些微的差異。事實上，大部分的人很難分辨兩者的不同。
(A)過多的 (B)樸素的 (C)些微的 (D)恰當的
- (D) 難易度：難
解析：由於還有很多工作要做，馬克不情願地延後了與高中同學的同學會晚餐。
(A)此外；額外地 (B)一般地 (C)各自地 (D)不情願地
- (C) 難易度：中
解析：如今在網路上發表無禮或冒犯性的言論很可能會讓您陷入法律困境。
(A)拳擊 (B)許可 (C)言論；評語 (D)部分
- (A) 難易度：難
解析：公司做了很多調查以更好地定義他們的目標客戶，也就是了解誰更有可能購買他們的產品。
(A)定義 (B)包含 (C)發動；發射 (D)推廣；促銷
- (D) 難易度：中
解析：即便過了數十年，我仍然對高中畢業那天有鮮明的記憶，就好像那是昨天一樣。
(A)明亮的 (B)正常的 (C)現今的 (D)鮮明的
- (A) 難易度：易
解析：藉由重複和誇張的手勢，茱蒂在她簡短的演講中強調我們如何增加銷售量。
(A)強調 (B)意圖 (C)進口 (D)維持；蒙受
- (A) 難易度：中
解析：我們本來沒料到他這麼快就想出解答，現在我們對他的聰明都感到印象深刻。
(A)聰明；光彩 (B)障礙 (C)說服 (D)物質
- (B) 難易度：難
解析：在我拒絕他的邀請後，他變得非常疏遠，這些天我們幾乎不說話。
(A)內疚的；有罪的 (B)疏遠的；遙遠的 (C)實際的 (D)樂觀的
- (A) 難易度：中
解析：操作重型機械的工人被提醒在工作前不要喝酒，或服用可能使他們昏昏欲睡的藥物。
(A)操作；經營 (B)創立 (C)提議；求婚 (D)預留

二、綜合測驗

第11.至15.題為題組

在整個城市中，人孔就是路邊的圓形或長方形金屬覆蓋的孔洞。它們提供通往地下公共設施系統的通道，例如下水道、排水溝，或水電設施管線。它們是不可或缺的，因為它們讓工人們能夠進入地下空間並進行清潔、維修和安裝等任務。人孔保養不善會導致淹水，或是行人或車輛掉入人孔等安全隱患。

在日本，出現了一種獨特的手機遊戲，目的鼓勵人們藉由發現和舉報受損的人孔來滿足基礎設施需求。該遊戲讓玩家探索周圍環境，找出損壞的人孔，並使用智慧手機通報這些人孔的位置。這種方法鼓勵大眾參與公民事務，進而幫助當局排定維修的優先順序。

雖然這個點子聽起來大有可為，但遊戲開發商和政府尚未解決可能出現的問題，例如假消息的風險，和忽略了很少玩家或根本沒有玩家參與遊戲的區域。必須小心面對這些挑戰，這樣我們才能確保所有道路使用者的安全。

目標：評量考生參酌上下文意發展，掌握各類詞彙 (含實詞、虛詞、慣用語及轉折詞等) 及語法應用的能力。

內容：手機遊戲與公眾事務參與的關聯。

- (A) 難易度：中
解析：(A)進入...；使用... (B)有...的傾向 (C)對...的強調 (D)...的功能
因為後文有提到人孔可以讓工人進到地下空間進行維修，故選(A)最符合上下文意。
- (D) 難易度：中
解析：(A)批判思考 (B)廣泛報導 (C)多重目的 (D)保養；維護不善
這一句後面提到安全危險，並舉出負面的例子，只有(D)能夠呼應後文，故選之。
- (D) 難易度：中
解析：(A)審視自己的人生 (B)加深他們的知識 (C)拓展社交圈 (D)探索他們的周遭環境
這題須仰賴上下文意，知道這款手機遊戲的目的是什麼，並且配合空格後面提到的「指認受損人孔」和「舉報位置」，就能選出最相關的(D)選項為正確答案。
- (B) 難易度：難
解析：(A)相較之下 (B)接著 (C)比方說 (D)充其量；至多
空格前後文意是時間前後的關聯：提升大眾對於公共事務的參與，政府就能夠安排維修的優先順序。其他選項皆不合理，故選(B)。
- (C) 難易度：難
解析：(A)喚醒 (B)改善 (C)忽略 (D)重獲；康復
空格後面提到較少或是沒有玩家的地區，加上第二段提到的遊戲內容，判斷選(C)最為合理。

重要字、詞與片語

manhole n. (地下管道或下水道供人出入檢修的) 人孔
circular adj. 環狀的 rectangular adj. 長方形的
utility n. (電、煤氣、鐵路等) 公共設施 sewer n. 排水道
indispensable adj. 不可或缺的 installation n. 安裝
hazard n. 危險 pedestrian n. 行人 emerge v. 浮現
infrastructure n. 基礎建設 civic adj. 公民的
prioritize v. 視為優先事項 promising adj. 大有可為；有前途的
resolve v. 解決

第16.至20.題為題組

眾所皆知，蜜蜂對我們的生態系統很重要，而且牠們正面臨著來自現代農業日益劇增的威脅，如殺蟲劑。然而，我們許多人不知道的是，有些行業應該要為此負比較大的責任。

比方說，杏仁產業，對蜂群有特別不利的影響。把蜂群長途運輸到杏仁園以完成授粉的任務所造成的壓力對蜂群來說是一種潛在危害。這種長途運輸可能會給蜜蜂帶來壓力，進而使蜂群更容易受到疾病和害蟲的侵害。此外，由於牠們直接從棲息地被移走，所以除了杏仁花以外，有限的食物來源進一步削弱了蜂群。另一個問題是蜜蜂會接觸到殺蟲劑以及杏仁生產中使用的其他化學物質。

一種永續的解決方案是使杏仁園內的棲息地和物種更加多樣化和穩定。透過創造不同的生態系統，並在杏仁樹中引入其他昆蟲，至少我們可以確保蜜蜂有足夠的食物供給，從長遠來看，甚至可以降低杏仁的農藥使用量。

內容：種植杏仁對於蜜蜂的危害。

16. (B) 難易度：中

解析：(A)因此 (B)然而 (C)此外 (D)首先

前文提到廣為人知的事實，空格後面卻說我們很多人不知道的事情，前後屬於轉折語氣，故選(B)。

17. (C) 難易度：中

解析：這一題考分詞構句的概念，原本句子應為 ..., and it hence makes ...，省略連接詞和主詞之後，makes 主動改成 making。因為 hence 是副詞，不影響分詞構句的使用。

18. (D) 難易度：難

解析：(A)面對需求的增加
(B)在自然環境中成長
(C)被養蜂人細心照顧
(D)從棲息地被移除

這題須仰賴上下文意判斷。空格後面提到杏仁花是唯一的食物來源，應可推得是因為前文所述，蜂群被長途運輸到杏仁園授粉的緣故，故選之。其他選項在空格前後文無法找到對應的出處或指涉。

19. (C) 難易度：中

解析：(A)培養；栽種 (B)傳遞
(C)暴露；接觸 (D)限制

因空格後文提到殺蟲劑，故選(C)最為合理。

20. (B) 難易度：難

解析：(A)值得的 (B)多元的
(C)令人愉悅的 (D)特別的

本句可以視為本段主題句。(B)選項可以和後文的 various ecosystems 和 other insects 呼應，故選之。

重要字、詞與片語

ecosystem <i>n.</i> 生態系統	agricultural <i>adj.</i> 農業的
pesticide <i>n.</i> 殺蟲劑	industry <i>n.</i> 產業
shoulder <i>v.</i> 肩負	
almond <i>n.</i> 杏仁	adverse <i>adj.</i> 負面的
colony <i>n.</i> 群	
orchard <i>n.</i> 農園	pollination <i>n.</i> 授粉
vulnerable <i>adj.</i> 易受...影響的；脆弱的	
sustainable <i>adj.</i> 永續的	stable <i>adj.</i> 穩定的

三、文意選填

第21.至30.題為題組

安寧照護是指為絕症患者及其家人或看護人員提供的一種專業和富有同情心的醫療照顧和支持形式。

安寧患者受益於更多21. 個人的關注和根據他們的需求量身訂做的服務。會有一個專門的團隊親自照顧每位患者，同時考慮到他或她的個人喜好以及病史。通常會為患者提供有效的22. 症狀管理，例如疼痛，以確保最佳的舒適度，並幫助他們進行日常活動。除了提供實質的幫助，安寧照護還為患者23. 提供精神支持，同時照顧他們的心理健康。熟練的專業人員提供一對一的談話或諮詢，以幫助患者24. 面對在生命盡頭可能面臨的情緒挑戰。

患者家屬和看護也能得到寶貴的支持和教育。例如，喘息服務讓看護人員進行必要的休息，以免他們25. 不堪重負和疲憊不堪。後續服務還幫助他們面對患者離世後的26. 悲痛。總而言之，醫護人員和社工在整個過程中對安寧照護患者的27. 同理心，讓他們的家屬感到安心。

然而，由於文化和宗教信仰，有些人對安寧照護的概念持保留態度。他們可能28. 擔心會加速死亡，或擔心疼痛管理不當。他們可能反而29. 更喜歡積極的療程，或者寧願不惜一切代價延長患者的生命。其他人則擔心，一旦患者變得幾乎無法洗澡或自己進食，安寧照護是否有助於維護患者的30. 尊嚴或自尊。無論人們遇到什麼問題，不可否認的是，安寧照護對患者及家屬都很重要，因此會一直存在。

目標：評量考生依據篇章段落的文意發展，掌握實詞詞彙運用的能力。

內容：安寧照護的好處與人們看法。

詞彙選項：

(A)擔心；顧慮	(B)受不了；不知所措	(C)偏好	(D)同理心
(E)個別的	(F)提供；延伸	(G)症狀	(H)處理
(I)悲傷	(J)尊嚴		

21. (E) 難易度：中

解析：這一格要填形容詞，修飾後面的名詞 attention。本句也可以視為本段主題句，空格後面那一句，還有更後面的 one-on-one talks，都是指接受安寧照護的病人可以得到比較多個人的關注，故選(E)。

22. (G) 難易度：中

解析：這一格要填名詞。空格後面的 such as pain 為重要線索，選擇(G)最為合理。

23. (F) 難易度：中

解析：這一格要填動詞。句子開頭的 Beyond 可視為一個線索，空格後面與 to 的搭配可視為第二個線索。extend A to B 即將 A 延伸到 B，或是將 A 提供給 B 的意思，符合前後文意，把對於病患的服務範圍延伸到其他面向，故選之。

24. (H) 難易度：難

解析：這一格要填動詞。受詞是挑戰，故選 address，表示「處理；應付」之意。

25. (B) 難易度：中

解析：這一句話提到安寧照護也提供讓家屬休息的選項，以免他們覺得太累或受不了，屬合理推斷，且空格後面的 worn out 「筋疲力盡的」也可以作為線索之一。

26. (I) 難易度：易

解析：這一題要選名詞。句子後面提到病患的離世，故選 grief 「悲傷」作為家屬的的心情最合理。

27. (D) 難易度：中

解析：這一題考名詞。醫療人員和社工提供給病人家屬的應該是「同理心」為最適合的選項。

28. (A) 難易度：難

解析：這一題考名詞。空格前後句和這一句都在討論一般人對於安寧照護的負面印象，加上搭配詞 raise + concern 的觀念，故這一題選 concerns 「擔心；顧慮」最適合。

29. (C) 難易度：中

解析：空格前面兩句都在討論一般人接受安寧照護的原因，加上這句有 instead 「反而」作為轉折，所以選擇 favor 「偏好」最為合理。後半句的 prefer 一字也可以視為線索之一，表示這一句話主要討論安寧照護之外的選擇。

30. (J) 難易度：易

解析：這一題考名詞。空格後面提到當病人無法自己沐浴或是進食，需要人幫忙的時候。加上空格搭配的動詞是 preserve 「保存；保持」，故選 dignity 「尊嚴」最合理。

重要字、詞與片語

hospice care <i>n.</i> 安寧照護	
compassionate <i>adj.</i> 有同情心的	
tailor <i>v.</i> 量身訂做	attend to <i>v.</i> 照顧
optimal <i>adj.</i> 最佳的	spiritual <i>adj.</i> 靈魂的；精神的
counseling <i>n.</i> 諮商	invaluable <i>adj.</i> 無價的
subsequent <i>adj.</i> 後續的；往後的	
religious <i>adj.</i> 宗教的	aggressive <i>adj.</i> 激進的
prolong <i>v.</i> 延長	self-esteem <i>n.</i> 自尊

四、篇章結構

第31.至34.題為題組

雖然獲得米其林認可對於一位廚師或是一間餐廳來說可能是一項重大成就，但重要的是要考慮隨之而來的缺點。一個主要的缺點是經濟負擔。堅持米其林星級要求的標準需要付出高昂的代價。31. (A)從使用最優質的食材到僱用熟練的員工，開銷會迅速增加。這些額外成本會損害米其林榮譽可能帶來的潛在經濟利益。

另一個不利因素是對盈利能力的不確定影響。雖然米其林星級在業內被認為是一種至高無上的榮譽，但普通消費者在選擇餐廳時可能不會優先考慮餐廳是否有米其林的認可。**32. (C)**對顧客來說，有更具決定性的因素，如：地點、價格和個人喜好。事實上，通常與米其林星級餐廳的較高價格可能會讓一些無法或不願支付高價的潛在顧客望而卻步。

此外，我們也不能忽視餐廳員工面臨的更大壓力和有限的創作自由。畢竟，米其林給食客和烹飪界帶來了更高的期望。**33. (D)**能夠持續提供卓越的用餐體驗對於廚師和餐廳員工來說可能會令人受不了。這對於希望盡可能長時間留住經驗豐富且合格的員工的餐廳老闆來說，尤其令人擔憂。

34. (B)因此建議餐廳老闆在決定追求米其林認可之前好好想清楚。維持所需標準的成本和不同的消費者偏好會影響米其林星級餐廳的盈利能力。在追求或維持米其林認可度之前，餐廳應仔細評估權衡取捨。

目標：評量考生掌握篇章的組織架構與理解文意脈絡的能力。

內容：探討米其林認可對餐廳的好壞影響。

31. (A) 難易度：中

解析：空格前兩句的 *financial burden* 「財務負擔」和 *high price tag* 「高價」呼應到(A)選項當中的 *the expenses can quickly add up* 「開銷快速增加」，而空格後面的 *These additional costs* 也可以視為指涉(A)選項中提到的兩點開銷增加的原因。

32. (C) 難易度：中

解析：空格前面一句提到消費者在選擇餐廳的時候，不一定會考慮是否有米其林的認可，(C)選項說明了其他可能考慮的因素，符合上下文意，故選之。

33. (D) 難易度：中

解析：這一段和前面一段都是討論米其林認可可能帶來的負擔。空格後面提到餐廳老闆可能留不住好員工，選項當中，只有(D)討論到餐廳員工的感受。

34. (B) 難易度：中

解析：這一段目的作為本文的結論段落。(B)可以作為前面幾段的摘要，也可以呼應空格後面的提醒，故選之。

重要字、詞與片語

<i>recognition n.</i> 認可	<i>downside n.</i> 缺點
<i>uncertain adj.</i> 不確定的	<i>profitability n.</i> 可營利性
<i>superb adj.</i> 絕佳的	<i>prioritize v.</i> 視為優先事項
<i>establishment n.</i> 建立；店家	<i>premium n.</i> 高價
<i>diner n.</i> 用餐顧客	<i>culinary adj.</i> 烹飪的
<i>consistently adv.</i> 一致地	<i>exceptional adj.</i> 絕佳的
<i>demanding adj.</i> 苛求的	<i>qualified adj.</i> 符合資格的
<i>varying adj.</i> 不同的	<i>retain v.</i> 保持

五、閱讀測驗

第35至38題為題組

雪人蟹是一種迷人的深海生物，棲息在海洋深處。雪人蟹具有與眾不同的外觀，使其有別於其他生物。牠最顯著的特徵是牠身體上密密麻麻覆蓋著毛髮狀剛毛，呈橢圓形，顏色較淡或偏白色。雪人蟹超大且多毛的蟹有助於牠從水中捕獲微小的生物和粒子。相較之下，據信雪人蟹的腿在進化過程中已經大幅縮小了。此外，牠細長的長觸角上有小眼睛，可以感受極端高壓、黑暗和高溫等具有挑戰性的環境。

雪人蟹在深海生態系統中發揮著至關重要的作用。有別於大型的海洋動物如鯊魚和鯨魚，雪人蟹主要是食腐動物，依靠它們的蟹在海底梳理，尋找動物殘骸還有腐爛的有機物。透過食用和回收死去的動物或植物的殘骸，雪人蟹有助於防止疾病傳播和淨化環境。此外，雪人蟹還在其毛茸茸的剛毛中充當特殊細菌的宿主，彼此形成共生關係。也就是說，這些細菌從雪人蟹身上的化合物中獲取能量和營養，而雪人蟹也可從細菌產生的有機分子中獲益。

儘管具有非凡的適應能力，雪人蟹在其深海棲息地仍面臨著多種威脅。一個重要問題與深海採礦活動有關。隨著人們對深海礦物和資源開採的興趣日益濃厚，雪人蟹棲息地的脆弱生態系統

正面臨破壞和干擾的風險。氣候變化也構成威脅。雪人蟹對特定條件的依賴使其特別容易受到這些生態系統中任何破壞的影響。目前，有各種努力來保護受威脅的雪人蟹，包括更密切的監測和推行永續的捕魚方式。這些努力長久下來是否會得到回報，將由時間來證明。

目標：評量考生綜合運用詞彙（含慣用語）、語意、語法、語用以及篇章結構的知識，理解文意脈絡、擷取文章重要訊息，並加以分析、比較與推理的能力。

內容：神秘雪人蟹的介紹以及面對的生存危機。

35. (A) 難易度：易

解析：下列何者最有可能是雪人蟹？

答案選(A)的線索在於文章第一段裡的敘述，提到有毛茸茸的蟹、橢圓身形、身體色澤、縮小的腳、身上的長觸角和刺毛。

36. (B) 難易度：中

解析：根據本文，下列何者為真？

(A) 雪人蟹位於海洋食物鏈的頂端。
(B) 雪人蟹生活在險峻或惡劣的環境中。
(C) 眾所周知，雪人蟹以身形更大的魚為食。
(D) 雪人蟹近來瀕臨絕種。

答案(B)的出處在於第一段最後一句。第二段第二句提出鯊魚和鯨魚和雪人蟹比較，且後文也有提到雪人蟹的覓食方式，應可推得雪人蟹位於海洋食物鏈的底端，因此選項(A)錯誤。選項(D)在文章當中並未提及，面臨威脅或挑戰不等於瀕臨絕種。

37. (A) 難易度：易

解析：以下哪些關係可以描述為第二段當中所提到的「互利共生」？

(A) 動物們互相提供必要的條件來幫助彼此生存。
(B) 動物為了適應環境而發展出特殊的器官。
(C) 由於自然棲息地缺乏食物，動物正在迅速死亡。
(D) 動物會根據周圍環境改變膚色。

38. (D) 難易度：易

解析：本文最後一段的主旨為何者？

(A) 為確保雪人蟹的生存做出了多項努力。
(B) 人類活動對雪人蟹有負面影響。
(C) 雪人蟹對環境的變化愈來愈敏感。
(D) 自然和人為的挑戰都威脅著雪人蟹。
選項(A)和(B)僅為本段提到的細節，無法作為本段的主旨。(C)未在本段中明確提到，且也不是主旨。

重要字、詞與片語

<i>distinctive adj.</i> 特別的	<i>striking adj.</i> 驚人的
<i>dense adj.</i> 濃密的	<i>bristle n.</i> 剛毛
<i>oval n.</i> 橢圓	<i>pale adj.</i> 蒼白的
<i>claw n.</i> 蟹；爪子	<i>organism n.</i> 微生物
<i>shrink v.</i> 縮小	<i>evolution n.</i> 演化
<i>extreme adj.</i> 極端的	<i>scavenger n.</i> 食腐動物（吃其他動物屍體的動物，本身不會獵捕食物）
<i>scrap n.</i> 碎片	<i>decay v.</i> 腐爛
<i>remains n.</i> 殘骸	<i>symbiotic adj.</i> 互利共生的
<i>derive v.</i> 取得	<i>compound n.</i> 複合物
<i>adaptation n.</i> 適應	<i>mining n.</i> 採礦
<i>disturbance n.</i> 干擾	<i>disruption n.</i> 打斷
<i>conserve v.</i> 保育；節約	<i>implement v.</i> 施行

第39至42題為題組

河內塔的謎題可以追溯到一間位於印度的貝拿勒斯的一座古神廟。根據傳說，寺內矗立著一座塔，塔上整齊地堆放著金圓盤，僧人被賦予了一項非凡的任務，就是將整座塔上的金圓盤移到位於寺院的另一端一座沒有圓盤的塔上。

河內塔謎題的規則簡單明瞭但也有限制。首先，一次只能移動一個圓盤。其次，一個圓盤只能放在一個較大的圓盤或空棒上，禁止將一個較大的圓盤放在較小的圓盤上。當所有圓盤都移到最後一根木棍或木釘上時，謎題就解決了，所有圓盤都按相同的大小順序放置。河內塔謎題的挑戰是以盡可能少的步驟完成。

幾天變成了幾週，幾週又變成了幾個月，僧侶們在這個令人費解的謎題中苦苦掙扎。他們的希望開始減弱，直到一個小男孩出現，他自願要解決這個難題。憑藉堅定的專注力和非凡的技巧，

他小心翼翼地移動圓盤，極其精確地遵守規則。當最後一張圓盤找到它的位置時，一道道的光束吞噬了神殿，象徵任務的完成以及世界的終結。

河內塔謎題在 19 世紀由法國數學家愛德華·盧卡斯引入西方世界後引起了國際關注。以對休閒數學的興趣而聞名的盧卡斯推廣了這個謎題。後來河內塔謎題在數學、電腦科學、問題解決和教育方面都有其應用。該謎題旨在增強批判性思維、空間觀念和邏輯推理，現在被廣泛用於娛樂和教育目的。具有很大的吸引力以及悠久的歷史，河內塔絕對不只是一道有趣的謎題而已。

內容：數學謎題河內塔的典故和玩法。

39. (B) 難易度：中

解析：本文的最佳標題為何者？

- (A)「河內塔，一個歷史地標。」
- (B)「用途多樣的智力挑戰。」
- (C)「數學如何幫助提高我們的生活品質。」
- (D)「數學界的傳奇人物們。」

本文主要介紹河內塔謎題的由來、玩法，還有它的應用，所以選項(B)最能呼應河內塔謎題的本質。

40. (B) 難易度：中

解析：根據本文，下列何者關於河內塔謎題為非？

- (A)內容是在不同桿子間移動尺寸不一的圓盤。
- (B)它和越南的河內市有歷史的淵源。
- (C)它一開始不是被當作數學的教材。
- (D)它的流行可以歸功於一位法國學者。

選項(A)的出處在第二段；選項(C)的出處在第一段，此謎題的典故源自於一個古老的傳說，數學的應用在近代才出現；選項(D)的出處則在最後一段。文章當中並未提到越南的河內市，而是印度的一處地名，故選項(B)為非。

41. (C) 難易度：中偏難

解析：下列何者在文章中有被提到？

- (A)為什麼僧侶試圖解決河內塔。
- (B)為什麼解開謎題意味著世界末日。
- (C)這個謎題在過去幾百年內的發展。
- (D)如何用盡可能少的步驟解決這個難題。

最後一段第一句點出 19 世紀，後面幾句也有 Later on 和 now 等代表時間的副詞，表示這段在說明河內塔謎題在 19 世紀後衍生的不同應用。

42. (D) 難易度：難

解析：下面何者是玩河內塔謎題的正確步驟？

- (A)步驟 1：① 步驟 2：② 步驟 3：④ 步驟 4：⑥
- (B)步驟 1：① 步驟 2：③ 步驟 3：④ 步驟 4：⑤
- (C)步驟 1：① 步驟 2：③ 步驟 3：② 步驟 4：⑤
- (D)步驟 1：① 步驟 2：④ 步驟 3：⑤ 步驟 4：③

文章第二段有提到河內塔解謎的規則，明確規定一次只能移動一個圓盤，且小圓盤只能放在大圓盤上面。

重要字、詞與片語

neatly <i>adv.</i> 整齊地
stack <i>v.</i> 堆；疊
assign <i>v.</i> 指派
disk <i>n.</i> 圓盤
straightforward <i>adj.</i> 直接的
placement <i>v.</i> 放置
wane <i>v.</i> 衰退 precision <i>n.</i> 精準 ray <i>n.</i> 光束
devour <i>v.</i> 吞沒 recreational <i>adj.</i> 娛樂的
spatial <i>adj.</i> 空間的 extensively <i>adv.</i> 廣泛地

第43.至46.題為題組

作為一種社會現象，取消文化的核心概念是透過公開批評和撤回支持來讓個人或組織對其行為或言論負責。取消文化最早可回溯到 2010 年代初期，當時社群媒體平臺為邊緣化的聲音提供了一種發聲管道。在這樣的文化下，那些曾經被噤聲、忽視或剝奪權利的人受到鼓勵，進而站出來揭露和挑戰過去某些公眾人物歧視性或是冒犯性的行為。

一宗涉及美國喜劇演員凱文哈特的事件就是取消文化的一個案例。當他被宣布獲邀擔任奧斯卡頒獎典禮主持人時，他以前一些恐同的推特文章被人們起底，導致大眾嚴厲批評並要求把他換掉。哈特最初拒絕道歉，但最終迫於壓力讓出主持棒。凱文的案例引發了一場關於幽默感、負責任和社群媒體影響力的辯論。這個案例清楚顯示取消文化如何快速影響公眾人物，但也同時促使大眾思考公平性和社群媒體所扮演的角色。

如今，大家對於取消文化的優點似乎抱持著分歧的意見。有些人認為，取消文化是重要工具，讓人們為自己曾犯的錯付出代價。他們相信取消文化可以促進社會進步，並鼓勵建立一個更安全、更包容的社會。其他人則認為取消文化會導致言論自由受到壓制，以及引發恐懼和自我審查的氛圍。他們認為，取消文化現在要挖出人們過去做過或說過的事情，往往並沒有考慮完整的背景因素。他們爭論說，取消文化通常仰賴片面證據和資訊，和暴民心態，經常對個人造成不公平的後果。無論我們站在取消文化的哪一邊，誰都不能否認，在這個互聯互通的世界裡，我們必須謹言慎行。

內容：取消文化的影響以及大眾看法。

43. (A) 難易度：中偏難

解析：當某人被「邊緣化」代表什麼意思？

- (A)某人被視為不重要。
- (B)某人被認為是團體中的麻煩製造者。
- (C)某人吸引了很多不必要的關注。
- (D)某人因其過去的錯誤而受到批評。

原出處的 *marginalized voices* 在文章後句可以找到文意線索，也就是後面所提到的「those who were once silenced, ignored, or deprived of their rights」(那些曾經被噤聲、忽視或剝奪權利的人)。

44. (C) 難易度：中

解析：以下哪種情況是取消文化起作用的典型案例？

- (A)名人靠著在每個禮拜的影片批評當局來賺錢。
- (B)一位食物小販因其多年來秘密慷慨行善而聞名。
- (C)一名政客因犯罪行為在網上公開而被迫辭職。
- (D)成績差的學生在班級群組中被同學霸凌。

這題可以從第一段的定義，還有第二段舉的例子來找出最相似的案例。取消文化目的在於要名人為自己過往的言行負責，故選(C)最符合文意。

45. (D) 難易度：易

解析：下列何者沒有在本文中提到？

- (A)取消文化的定義。
- (B)取消文化的起源。
- (C)對取消文化的不同看法。
- (D)作者自己對取消文化的批評。

選項(A)和(B)出處皆在第一段，(C)出處在第三段，故選(D)。

46. (B) 難易度：中偏難

解析：從本文最後一段可以推論出什麼？

- (A)政府能夠扮演重要角色來鼓勵取消文化。
- (B)有些人可能因為取消文化而遭受不公正或不必要的痛苦。
- (C)一個人過去的記錄在取消文化中似乎無關緊要。
- (D)公眾似乎總是站在受虐者的那一邊。

選項(B)呼應反對取消文化的意見，如文中最後一段：「They contend that it often operates based on incomplete evidence or information, and mob mentality, leading to unfair consequences for individuals.」故選之。

重要字、詞與片語

statement <i>n.</i> 陳述 withdrawal <i>n.</i> 撤離；撤回
means <i>n.</i> 方式；方法 marginalized <i>adj.</i> 被邊緣化的
deprive <i>v.</i> 剝奪 public figure <i>n. phr.</i> 公眾人物
discriminatory <i>adj.</i> 歧視性的
homophobic <i>adj.</i> 恐同的 spark <i>v.</i> 激發
accountability <i>n.</i> 責任 divided <i>adj.</i> 分歧的
inclusive <i>adj.</i> 包含的 self-censorship <i>n.</i> 自我審查
context <i>n.</i> 前後文 mob <i>n.</i> 暴民

第貳部分、混合題
第47.至50.題為題組

現今，不難發現慈善機構在傳統媒體和社群媒體平臺上投放廣告。人們不禁懷疑這是否為一種適當或必要的做法，因此對這個問題進行了激烈的討論。以下是不同人士的看法。

(A)林：「廣告是遊戲規則的改變者！我們從來沒看過比廣告更有效的工具來增加人們捐款或是施予零錢的意願。透過電視、報紙和社群媒體，慈善機構可以接觸到廣泛的觀眾群、激起情緒並爭取支持。我們去年光靠 Facebook 廣告就募了超過一千萬元，我們今年打算擴大廣告活動。」

(B)桑托斯：「慈善機構應該進行徹底的研究和分析，以確定廣告是否符合他們的目標，並且能吸引到目標觀眾。很重要的事是要檢視潛在的收益和成本，並做出明智的決定，才能把他們的影響放到最大。」

(C)茱蒂：「讓我們考慮一下財務現實。雖然廣告有其優勢，但我們不能忽視所涉及的巨大成本。慈善機構通常預算都很有限，在廣告和直接提供援助間進行權衡及取捨。」

(D)珍：「想想看：具有說服力的敘事和引人入勝的視覺效果可以激發情感。用親身經驗還有一些能夠讓觀眾產生共鳴的故事，慈善機構能夠傳達迫切感和重要性，觀眾可能就會感動落淚。慈善機構也能夠與觀眾建立深厚的感情連結，進而培養了忠實的支持者以進行持久的改變。」

(E)俊：「雖然廣告有它的一席之地，但沒有什麼比得上與人的連結。慈善機構應該優先考慮面對面的接觸，讓人們親身體驗他們的工作，進而培養鞏固的信任感和支持。」

目標：本大題旨在評量考生綜合運用詞彙（含慣用語）、語意、語法、語用以及篇章結構的知識，理解文意脈絡、擷取文章重要訊息，並加以分析、比較與推理的能力。

內容：討論慈善機構是否應該製作與投放廣告。

47. game-changer 難易度：中偏難

解析：上述觀點中哪個字的意思是「能夠戲劇性地扭轉局勢的某人或是某物，通常是帶來正面或是令人想要的結果」？Lin 在訪談當中提到自己因為廣告而大幅提升捐款成效的個人經驗，大力讚揚廣告效果。前文提到的 game-changer 最能夠符合題目要求，故選之。

評分原則：須全對才給分，共 2 分。

48. -49. 請將上列人名依照他們的看法填入下列空白處。

48. Joon 難易度：易

解析：_____ 最有可能建議慈善機構舉辦活動，讓潛在捐款人與可能受益的人（例如弱勢群體）面對面接觸。Joon 在訪談當中提到的 personal connections 還有 face-to-face engagement 都是答題的線索。

49. Jane 難易度：中

解析：_____ 最有可能建議聘請一位導演來拍攝能夠連接觀眾情感的短片來當作廣告材料。Jane 是唯一適合填入此題的受訪者，因為她所提到的關鍵字，如：story-telling、visuals、spark feelings、first-hand accounts、personal stories 等都和拍攝短片有關。

評分原則：每小題 2 分，各小題須全對才給分，共 4 分。

50. (A)(D) 難易度：中

解析：請根據上述訪談結果，選出正確的陳述。

(A)至少一位受訪者擔心拍攝廣告對於慈善機構來說可能負擔不起或不切實際。

(B)有一名受訪者深信這項討論的趨勢很快就會消退。

(C)有受訪者指出政府有需要立法規範投放廣告的慈善機構。

(D)沒有一個受訪者以自己過去的失敗作為反對利用廣告增加捐款的論點。

(E)所有的受訪者均曾經或者目前任職於慈善機構。根據訪談結果，Santos 和 Judy 都有提到財務上的顧慮。關鍵字如：costs、financial reality 和 limited budgets 等。另外，只有 Lin 明確提到自己成功的經驗，其他的受訪者都只有提出建議或個人觀點。沒有任何受訪者明確指出自己曾經失敗的事蹟。所有受訪者中，只有 Lin 明顯是慈善機構的員工。

重要字、詞與片語

outlet *n.* 出口 heated *adj.* 激烈的
game-changer *n.* 扭轉局勢的人事物 rally *v.* 召集
thorough *adj.* 詳盡的 trade-off *n.* 取捨
captivating *adj.* 吸引人的 visual *n.* 視覺呈現
urgency *n.* 急迫性 nurture *v.* 培育

第參部分、非選擇題

一、中譯英

1. My colleague / coworker // is an adventurous tourist / traveler (a tourist / traveler who enjoys / likes / loves adventures), // often / frequently / usually visiting (and often visits) countries // that are unfamiliar to most Taiwanese people (that / which most Taiwanese people are not familiar with).
2. Despite / In spite of potential risks (Though there are potential risks), // traveling to those places // can satisfy his (her) curiosity // and enrich his (her) life.

二、英文作文

The picture is about a school fair attended by students, their friends and teachers. Students play different roles in this event, with some collecting money from customers, others busy preparing food ingredients for mouth-watering delicacies, and still others distributing flyers to promote their special offerings. Some stands sell local treats or desserts, while others offer interesting games. With people chatting happily and enjoying the food to their hearts' content, everyone, regardless of role or age, seems to have a great time at this school fair.

Personally, I believe it's a good idea to hold a school fair for a number of reasons. First, for students, a school fair means a rare opportunity to learn about teamwork and time management. Throughout the preparation process, students get to negotiate on different options, calculate their budget, and learn about fair labor division. They can also have fun meeting with their old schoolmates and catching up on their time apart. For the school, on the other hand, holding a school fair is a chance to connect with parents and alumni, who may provide invaluable support in helping with school affairs and operations. Teachers can also take a short break from the routine of giving tests and marking papers to enjoy the occasion with their students. It seems holding a school fair does a lot of good to all parties involved.

評分原則：本大題總分 20 分，採整體式評分，分為五等級：特優（19-20 分）、優（15-18 分）、可（10-14 分）、差（5-9 分）、劣（0-4 分），閱卷委員於閱讀完考生試卷後，初步決定一個分數，再以各分項評分標準（詳見下表）檢閱是否符合此分數。另外，字數明顯不足，扣 1 分。未分段，扣 1 分；寫多段，不扣分。

英文作文評分指標

等級 項目	優	可	差	劣
內容	主題(句)清楚切題,並有具體、完整的相關細節支持。(5-4分)	主題不夠清楚或突顯,部分相關敘述發展不全。(3分)	主題不明,大部分相關敘述發展不全或與主題無關。(2-1分)	文不對題或沒寫(凡文不對題或沒寫者,其他各項均以零分計算)。(0分)
組織	重點分明,有開頭、發展、結尾,前後連貫,轉承語使用得當。(5-4分)	重點安排不妥,前後發展比例與轉承語使用欠妥。(3分)	重點不明,前後不連貫。(2-1分)	全文毫無組織或未按提示寫作。(0分)
文法、句構	全文幾無文法、格式、標點錯誤,文句結構富變化。(5-4分)	文法、格式、標點錯誤少,且未影響文意之表達。(3分)	文法、格式、標點錯誤多,且明顯影響文意之表達。(2-1分)	全文文法錯誤嚴重,導致文意不明。(0分)
字彙、拼字	用字精確、得宜,且幾無拼字、大小寫錯誤。(5-4分)	字詞單調、重複,用字偶有不當,少許拼字、大小寫錯誤,但不影響文意之表達。(3分)	用字、拼字、大小寫錯誤多,明顯影響文意之表達。(2-1分)	只寫出或抄襲與題意有關的零碎字詞。(0分)

新竹區高級中等學校

112 學年度學科能力測驗聯合模擬考試

英文考科

請於考試開始鈴響起，在答題卷簽名欄位以正楷簽全名

—作答注意事項—

考試範圍：第 1 ~ 4 冊

考試時間：100 分鐘

作答方式：

- 選擇題用 2B 鉛筆在「答題卷」上作答；更正時，應以橡皮擦擦拭，切勿使用修正液（帶）。
- 除題目另有規定外，非選擇題用筆尖較粗之黑色墨水的筆在「答題卷」上作答；更正時，可以使用修正液（帶）。
- 考生須依上述規定劃記或作答，若未依規定而導致答案難以辨識或評閱時，恐將影響成績。
- 答題卷每人一張，不得要求增補。

選擇題計分方式：

- 單選題：每題有 n 個選項，其中只有一個是正確或最適當的選項。各題答對者，得該題的分數；答錯、未作答或劃記多於一個選項者，該題以零分計算。
- 多選題：每題有 n 個選項，其中至少有一個是正確的選項。各題之選項獨立判定，所有選項均答對者，得該題全部的分數；答錯 k 個選項者，得該題 $\frac{n-2k}{n}$ 的分數；但得分低於零分或所有選項均未作答者，該題以零分計算。

祝考試順利



版權所有 · 翻印必究

第壹部分、選擇題（占 62 分）

一、詞彙題（占 10 分）

說明：第 1. 題至第 10. 題為單選題，每題 1 分。

1. A South African entrepreneur began a rhino breeding project decades ago and so far has _____ to increase his stock of the animals.
(A) admitted (B) dared (C) surrendered (D) managed
2. In a study that examined the effects of extreme _____ and deprivation on physical and mental health, an athlete volunteered to live in solitude in a cave 70 meters deep for three weeks.
(A) inhabitant (B) hostility (C) isolation (D) indifference
3. Scientists have discovered that plants emit sounds when they are stressed, but the sounds are at too high a _____ for the human ear to pick up.
(A) foundation (B) frequency (C) framework (D) feedback
4. A team of researchers found that forgetting no-longer-relevant information is beneficial as it keeps the brain working _____.
(A) smoothly (B) roughly (C) generally (D) primarily
5. Despite the beauty of the emerging buds signaling the arrival of spring, many people _____ this annual phenomenon due to the seasonal allergies it brings, such as hay fever.
(A) extend (B) cripple (C) dread (D) deserve
6. This species of bird is becoming increasingly _____, so a new law to protect these birds is to be introduced to prevent them from becoming extinct.
(A) realistic (B) rare (C) exclusive (D) intense
7. The National Federation of Teachers Unions is urging the government to abandon its bilingual nation policy for Taiwan by 2030, for this plan _____ with Taiwan's test-oriented system.
(A) corresponds (B) cooperates (C) coincides (D) clashes
8. Before deciding on the purchase, Ken conducted a thorough _____ of the car, examining its exterior as well as its interior, leaving no detail unnoticed.
(A) inspection (B) introduction (C) invasion (D) indication
9. On the night before the piano recital, Jane practiced _____, playing the same piece over and over again until she mastered it.
(A) collectively (B) continuously (C) conservatively (D) consistently
10. With her morning swim _____ disrupted by the pandemic, Lisa, in her 60s, took to weight training and has participated in several competitions so far.
(A) response (B) route (C) routine (D) resort

二、綜合測驗（占 10 分）

說明：第 11.題至第 20.題為單選題，每題 1 分。

第 11.至 15.題為題組

While it is common for the public to visit temples, many still remain uncertain about the proper way to worship. Often, people simply enter the temple and light incense without much consideration. However, there are some specific protocols and 11. for worshipping in temples.

One of them is following the principle of “Left Honored, Right Inferior.” When looking out from the temple, the doors on both sides are respectively called “Dragon Gate” and “Tiger Gate.” Entering through the Dragon Gate is believed to enable the worshipper to 12. the auspicious power of the dragon to ward off evil and invite good fortune. Exiting through the Tiger Gate channels the formidable energy of the tiger to suppress malevolent forces, 13. a rebirth or renewal. Besides observing the direction, one can also pay attention to the ornamentation on the walls beside the gates. Dragon gates often feature auspicious dragon sculptures, while tiger gates are 14. fierce tiger depictions.

By observing this custom and paying attention to the symbolic decorations, one can engage in worship 15. respect and invite positive energy. To demonstrate a devout attitude, you cannot never be too careful during temple visits.

11. (A) regulations (B) trials (C) etiquettes (D) adjustments
12. (A) take over (B) turn to (C) build on (D) tap into
13. (A) symbolizing (B) symbolized (C) to symbolize (D) having symbolized
14. (A) decorated with (B) composed of (C) accompanied by (D) provided with
15. (A) for (B) with (C) via (D) in

第 16.至 20.題為題組

Learning new course material is a challenge that students face every semester. Many students 16. traditional study methods like repetitive studying and re-reading notes or textbooks, believing that reviewing the same material repeatedly is the best way to retain information. However, research has indicated that there are more effective methods for long-term retention and successful retrieval of information.

One of the most powerful learning strategies to improve the retention and retrieval of information is retrieval practice. Retrieval practice involves actively recalling information from memory without consulting course materials, followed by a 17. accuracy check. The accuracy check must be done after the active recall, as it helps students identify the areas they need to improve.

To use retrieval practice, students can 18. methods such as making practice tests or flashcards, covering lecture slides to recall information, or focusing on the types of questions that will be on the exam. By incorporating such retrieval practice into their study routines, students can significantly improve their exam performance and long-term retention of course materials.

However, many students find retrieval practice uncomfortable and challenging. They may feel they are not learning the material when they get answers wrong. On the contrary, when they read and re-read the material, there is a(n) 19. of mastery. To change this, teachers must constantly remind students that repetitive studying doesn't involve the cognitive process that exams require, 20. retrieval practice reinforces neural pathways associated with learned information, leading to more permanent memory.

16. (A) make up (B) jot down (C) rely on (D) put forward
17. (A) simultaneous (B) prior (C) disruptive (D) subsequent
18. (A) reverse (B) employ (C) oversee (D) prescribe
19. (A) illusion (B) ideology (C) fraud (D) syndrome
20. (A) whether (B) while (C) unless (D) since

三、文意選填 (占 10 分)

說明：第21.題至第30.題為單選題，每題 1 分。

第21.至30.題為題組

For centuries, people have savored pretzels as a pastry that can be either sweet or savory. Despite their original knot-like shape, pretzels nowadays come in a diverse array of shapes and 21. . Some taste soft and fluffy, and others are hard and crisp like crackers. It is believed that pretzels originated in 610. At that time, a monk from Italy came up with *pretiola* to 22. his students to study harder. It was a snack made by rolling bread dough into long ropes and then twisting them into two loops. The monk saw *pretiola* as hands 23. in prayer over the chest. *Pretiola* consisted of basic 24. such as flour, salt, and water. For this reason, they became a 25. food choice during the month of Lent, when meat, dairy, and eggs were strictly forbidden. As a result, their popularity 26. , and they spread throughout Europe, finally reaching Germany, where they evolved into what we now know as pretzels. It was after German immigrants introduced them to Pennsylvania in the 1700s that pretzels 27. the world. Today, the worldwide pretzel industry has a value of nearly US\$500 million!

Pretzels are taken as a good-luck symbol in parts of Europe. On New Year's Day, it used to be customary for German children to wear necklaces made of pretzels. In Swiss, the interconnected loops of the pretzel are a representation of 28. love. This symbol is the source of the phrase "tying the knot."

These days, pretzels are available in an extensive range of flavors. They can be salted, dipped in chocolate, topped with nuts and seeds, or served with cheese 29. . They can also be found in a multitude of shapes, ranging from pretzel sticks to heart-shaped pretzels. Some even 30. letters! Pretzels have truly come a long way from their humble Italian beginnings. So don't go tying yourself in knots over them; grab some pretzels and dig in!

- (A) motivate (B) spread (C) eternal (D) crossed (E) took over
(F) surged (G) textures (H) suitable (I) ingredients (J) resemble

四、篇章結構（占 8 分）

說明：第31.題至第34.題為單選題，每題 2 分。

第31.至34.題為題組

The nature of life has always been a popular topic discussed in literature and art. 31. Set in the fictional town of Grover's Corners, the play brings the audience to take a look at the pieces of the life of the Gibbs and Webb families, residents in the town, through the passage of twelve years.

In the beginning of the play, Wilder describes the characters' childhood years and the innocence, and limitless possibilities that come with youth. The audience witnesses the dreams, hopes, and ambitions of young George Gibbs and Emily Webb. 32. However, as the play goes on, Wilder skillfully portrays the realities of adulthood and the challenges that accompany it. The audience experiences the characters' marriages, the strains of daily life, and the gradual erosion of their youthful ideals.

Wilder also presents a haunting depiction of the afterlife. In the play's final act, Emily, now deceased when giving birth to her and George's second child, is given the opportunity to revisit a day from her life.

33. However, not long after, she becomes overwhelmed by the realization that people still alive are unaware of the beauty and significance of the present moment. She cannot help but ask, "Do any human beings ever realize life while they live it?—every, every minute?"

34. From the first act, where the characters' hopes and dreams are presented with youthful enthusiasm, to the poignant final moments, the playwright imparts a message: our time on this earth is limited, so we must live fully and embrace every fleeting moment.

- (A) Their interactions are full of promise and budding romance.
- (B) This is also the case in Thornton Wilder's iconic play, "*Our Town*."
- (C) Throughout "*Our Town*," Thornton Wilder emphasizes the transient nature of life again and again.
- (D) Observing her loved ones, she notes her parents' youth and beauty and feels a nostalgic appreciation for everyday life.

五、閱讀測驗（占 24 分）

說明：第35.題至第46.題為單選題，每題 2 分。

第35.至38.題為題組

Vending machines have undergone significant evolution since their humble beginnings in the late 1800s. Originally operated with just a penny, these machines predominantly sold items such as cigarettes, peanuts, and small trinkets. Today, we commemorate the modest origins of vending machines and reflect on the remarkable journey of this technology over the past 100 years in the United States.

According to Kerry Segrave's *Vending Machines: An American Social History*, the first patent for an automatic vending device was filed in Britain in 1857. Interestingly, this patent was for a machine designed to dispense stamps rather than food. Shortly after, the concept of vending machines crossed the Atlantic. In 1888, Tutti-Frutti brand gum vending machines debuted in New York's train stations, quickly gaining popularity. This eventually led to the consolidation of 18 major vending machine companies into the colossal Autosales Gum in 1911.

In the 1930s, cold-beverage vending machines were introduced, followed by electrically-powered machines capable of maintaining cool temperatures before World War II. By the 1940s, soda vending machines boasted a wider array of options, yet one choice often remained **elusive**: coffee. Coffee production in vending machines proved challenging for the industry until the late 1940s when a machine was developed to blend a liquid coffee concentrate with hot water automatically. In the 1960s, manufacturers found a solution with single-cup coffee machines that used “pods” filled with ground-roasted coffee beans, overcoming the longstanding obstacle.

In early 21st century, vending machines started incorporating advanced technologies. For instance, in 2004, Mondelez, an international beverage and snack company, introduced a groundbreaking 3D printing machine that produced customized Oreo cookies based on “trending flavors” on Twitter. The National Automatic Merchandising Association predicts that future advancements, such as facial recognition software and interactive touchscreens, will enhance the personalized consumer experience. With significant progress made over the past century and a half, it is exciting to imagine what the next 150 years will bring.

35. How is the passage organized?

- (A) By cause and effect. (B) In the order of importance.
(C) In the sequence of time. (D) By classification.

36. Which of the following is closest in meaning to the word “**elusive**” in the third paragraph?

- (A) ineffective
(B) favorable
(C) unobtainable
(D) promising

37. Which of the following is **NOT** true according to the passage?

- (A) The first vending machine patented in the UK was not designed for selling food.
(B) To seize the trend of chewing gum vending machines, many companies chose to collaborate to meet the market demand around the 1910s.
(C) It was challenging to keep beverages inside vending machines at a certain low temperature before the 1930s.
(D) Coffee powder was favored over coffee pods by manufacturers of coffee vending machines in the 1960s.

38. What can be inferred from the passage?

- (A) Mondelez will continue to dominate the market of technology-integrated vending machines in the future.
(B) Standardization of products will be a focus in the application of technology-integrated vending machines.
(C) The application of 3D printing technology in smart vending machines will significantly improve the quality of products.
(D) Face-based AR technology will be applied to smart vending machines to enhance the consumer experience.

第39.至42.題為題組

Retailers are increasingly turning to artificial intelligence (AI) to improve their business operations. AI is being used to track the market price of products and adjust prices of thousands of items across a store based on changes in supply and logistics. It can forecast the ideal time to lower prices to maximize profits. Additionally, retailers are using AI to manage worker schedules, enable automated item checkout via computer vision, and recommend products to customers online.

Sam's Club recently debuted autonomous floor scrubbers that use computer vision to detect items that are missing from shelves, those that are low in stock or those that are mislabeled. The information is sent back to an **ecosystem** that could change workers priority list. The retailer also uses AI in its virtual voice assistant called Ask Sam, which workers can use to find prices, locate items, or help customers. In the future, AI could determine how many croissants workers should bake and alert them when the doughnut count is low.

However, AI-enabled systems are not always well-received. When Walmart introduced robot cleaners, store associates complained about malfunctions and the time it took to train the robots. Facial recognition systems have historically suffered flaws, often misidentifying people of color, which could lead to security unfairly targeting Brown and Black people.

The adoption of AI in the retail industry will impact jobs. Workers jobs are likely to be dictated by what machines deem most important. Workers will probably need to adjust to working with data and technology more frequently. AI could also mean more risks, such as algorithmic discrimination or adverse consequences in how different types of customers are treated.

Overall, AI will increase workforce productivity and reduce inconvenience for customers. Retailers need to be careful in their approach to the implementation of AI to ensure that it is a force for good.

39. What is the author's main purpose in writing this article?

- (A) To discuss the history of retail technology.
- (B) To discuss the impact of AI on the retail industry.
- (C) To highlight the risks of using AI in the retail industry.
- (D) To provide a guide on how to implement AI in retail businesses.

40. How does Sam's Club use AI in its operations?

- (A) To monitor employee productivity.
- (B) To determine store layout and design.
- (C) To assist in price and item inquiries.
- (D) To provide virtual reality shopping experiences.

41. Based on the passage, what is a potential risk of using AI in the retail industry?

- (A) Showing bias against individuals.
- (B) Not accurately adding up the prices of the items.
- (C) Leading to slow checkout lines.
- (D) Decreasing workforce productivity.

42. What does the word “**ecosystem**” mean in the 2nd paragraph?
- (A) A place where animals and plants live and interact with each other.
 - (B) A marketing campaign designed to increase brand awareness.
 - (C) A type of software program used to manage finances.
 - (D) A system of interconnected technologies that support a specific goal.

第43.至46.題為題組

Sperm whales are giants of the deep sea. As the largest toothed predators on Earth, they are widely known for their distinctive shape—a large, block-shaped forehead that makes up about one-quarter to one-third of their body length, a relatively small jaw that contains its cone-shaped teeth, and a single blowhole that is located on the left side of the front of their enormous head.

Sperm whales derived their name in the 18th century. During this time, commercial whalers made a significant discovery: the head of the sperm whale contained an enormous organ filled with a white liquid. The whalers mistook the fluid for the whale’s sperm and thus named the species “sperm whale.”

The white liquid, spermaceti, helps the whales make sounds for echolocation. However, it is also the presence of it that led to the misery of sperm whales. Because of spermaceti’s great value in applications in oil lamps, lubricants, and candles, from 1800 to 1987, sperm whales were relentlessly pursued by the whaling industry. Thousands of them were hunted, which nearly destroyed all sperm whale populations. It was not until the International Whaling Commission implemented a hunting moratorium that the sperm whale finally gained protection from such exploitation.

While whaling is no longer a major threat, sperm whales now face another threat from human activity—entanglement in fishing gear. Once a sperm whale becomes **entangled** in fishing gear, it may swim long distances dragging attached equipment, resulting in exhaustion and stress. In a worse situation, the entanglement may severely restrict the whale’s freedom of movement, which hinders its ability to dive and catch food, leading to malnutrition and weight loss. In the worst situation, this may cause the whale to fail to reach the surface to breathe. As a result, it may drown.

43. What aspects of sperm whales are discussed in the article?
- (A) Appearance → name → vocalization → lifespan
 - (B) Appearance → name → suffering → the current challenge
 - (C) Habitat → name → suffering → lifespan
 - (D) Habitat → name → vocalization → the current challenge
44. According to the passage, which of the following statements about sperm whales is true?
- (A) Their ability to navigate the surroundings is a critical finding in the 19th century.
 - (B) They were once a primary target of the commercial whaling industry.
 - (C) That their head contains valuable spermaceti is a mistaken belief.
 - (D) They were discovered because of their distinctive physical features.

45. Which of the following is the closest illustration of a sperm whale?

(A)

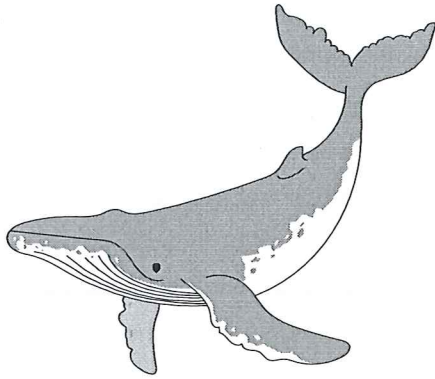

(B)

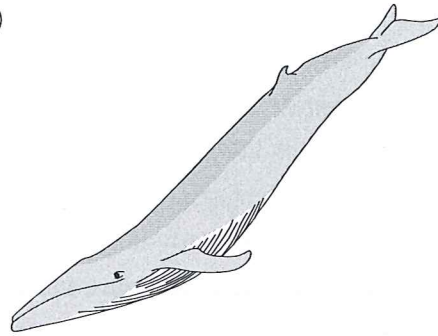

(C)

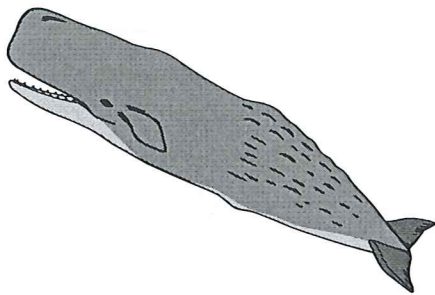

(D)

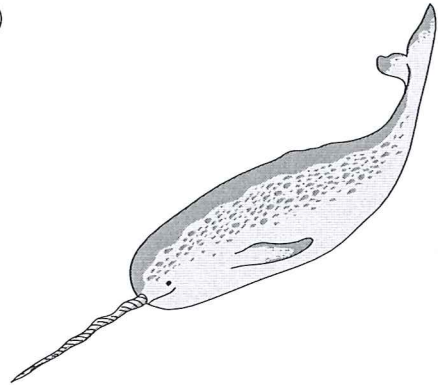

46. Which of the following is the closest in meaning to the word “**entangled**” in the last paragraph?

(A) be tied up

(B) be turned down

(C) be brought in

(D) be flipped over

第貳部分、混合題（占 10 分）

說明：本部分共有 1 題組，每一子題配分標於題末。限在答題卷標示題號的作答區內作答，並依規定用筆作答。

第47.至50.題為題組

Around 12,000 years ago, with the rise of settled agricultural communities, humanity began actively utilizing natural resources in large amounts. However, as the occurrence of a series of recent disasters—from the coronavirus pandemic to America’s deadliest wildfire in a century—has clearly demonstrated, human activities seem to have gone too far. Our interference with the natural world has increased the likelihood of transforming human activities into tragedy. We created the Anthropocene, and now we are witnessing the negative consequences of the Anthropocene.

So, what exactly is the Anthropocene? The Anthropocene, an epoch marked by the profound impact of human activities on Earth’s ecosystems, signifies a dramatic change in the relationship between humanity and nature. Coined in 2000 by Nobel laureate Paul Crutzen, the term combines “anthropos,” the Greek word for “human,” with “-cene,” the suffix used for geological epochs. Crutzen believed that humans have a huge responsibility as caretakers of Earth. He thought it was high time for a name change to reflect our role. In 2007, he also talked about the “great acceleration,” which means the growing effects of human actions on the planet since the mid-20th century.

To reinforce the idea of human beings being the major harm to Earth, a few months after Crutzen introduced the term, he collaborated with an American biologist, Eugene Stoermer, to further develop the concept in an article centered around the Anthropocene in the International Geosphere-Biosphere Programme's newsletter. They strongly argued that humanity had entered an unprecedented phase in the history of our planet, with humans becoming the primary driving force behind global changes. According to them, "without a major catastrophe, such as an asteroid impact or nuclear war, humankind would remain a major geological force for many millennia." At this point, the impact of the thought-provoking term was still quite underestimated. But the concept **took flight**. Scholars from various fields start to offer distinct perspectives on the Anthropocene. Geologists examine stratigraphic evidence to pinpoint the geological markers of this epoch. Ecologists study the ecological consequences of human actions, such as biodiversity loss and climate change. Social scientists delve into the socioeconomic factors that drive these transformations, while philosophers reflect on the moral and ethical dimensions of our role as planetary stewards.

In conclusion, the concept of the Anthropocene serves as a testament to our planet's susceptibility to human activities. It emphasizes the urgent need for collaboration involving different fields to address the multifaceted challenges posed by this epoch. Recognizing our responsibility, we must strive for sustainability, environmental stewardship, and holistic approaches that harmonize human progress with the preservation of Earth's ecosystems. Only through collective action can we forge a path towards a more resilient and harmonious future for all life on our shared planet.

47. As mentioned in the passage, we human beings are the creators of the Anthropocene, and now we are experiencing the harmful outcomes of our own creation. What are the negative consequences mentioned in this passage? (多選題, 2 分)

- (A) An uncontrolled fire that spreads rapidly and uncontrollably across vegetation, typically in forested or wildland areas.
- (B) A situation where a popular tourist destination becomes overwhelmed with an excessive number of visitors.
- (C) The decline in the variety and abundance of different species in a specific habitat or on a global scale.
- (D) A global outbreak of a disease that affects a large number of people across multiple countries or continents.
- (E) An unequal distribution or disproportionality of individuals between genders within a specific context, such as a population, workforce, or social setting.
- (F) An economic downturn or contraction characterized by a significant decline in economic activity across multiple sectors of an economy.

48. 請根據選文內容，從文章中選出兩個單詞 (word)，填入下列文句中的空格，並視語法需要作適當的字形變化，使句子語意完整、語法正確，且符合全文文意。(簡答, 4 分)

The notion of the Anthropocene highlights our planet's vulnerability to human activities and emphasizes the imperative of collaborative efforts across disciplines to confront the complex challenges presented by this epoch. Acknowledging our responsibility, we must endeavor to adopt (1) practices, foster environmental stewardship, and embrace holistic approaches that safeguard and (2) Earth's ecosystems while promoting human progress. Only through such comprehensive action can we forge a path that ensures the long-term preservation of our shared planet's delicate balance.

49. Which of the following is closest in meaning to “took flight” in the third paragraph? (單選題，2分)
- (A) volunteered
(B) decreased
(C) soared
(D) dived
50. Which of the following best describes the term “the Anthropocene”? (單選題，2分)
- (A) A geological epoch characterized by the impact of human activities on Earth’s ecosystems.
(B) A phenomenon that fosters interdisciplinary cooperation and technological progress.
(C) A catastrophic event caused by an asteroid impact or nuclear war.
(D) A newsletter article written by Paul Crutzen and Eugene Stoermer.

第參部分、非選擇題 (占 28 分)

說明：本部分共有二大題，請依各題指示作答。答案必須寫在「答題卷」標示題號之作答區內，作答時不必抄題。

一、中譯英 (占 8 分)

說明：依題號將以下中文句子譯成正確、通順、達意的英文。每題 4 分，共 8 分。

1. 因應全球暖化和空汙嚴重的議題，近期世界各國都宣布能源節約的目標。
2. 為達到能源節約的要求，各車廠都致力於電動車的發展。

二、英文作文 (占 20 分)

說明：依提示寫一篇英文作文，文長至少 120 個單詞 (words)。

提示：下面圖片所呈現的 2 個場景是假期出遊的熱門選項，請依自己的喜好選擇，寫一篇英文作文，文長約 120 個單詞。文分兩段，第一段描述兩張圖片中所呈現的場景；第二段則說明自己會選擇哪一個旅遊場景並說明理由。

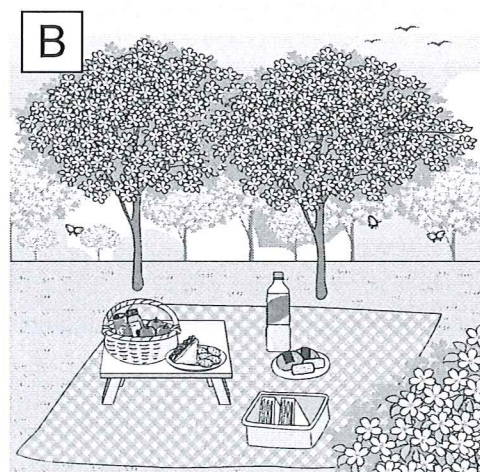
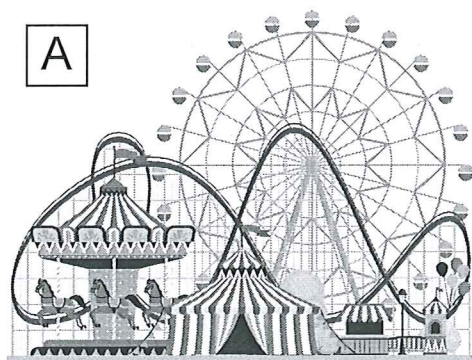

新竹區高級中等學校

112 學年度學科能力測驗聯合模擬考試

英文

英文
考科
參考
答案
暨
詳解

翰林出版事業股份有限公司



99362313-32

版權所有 · 翻印必究

英文考科詳解

1.	2.	3.	4.	5.	6.	7.	8.	9.	10.
(D)	(C)	(B)	(A)	(C)	(B)	(D)	(A)	(B)	(C)
11.	12.	13.	14.	15.	16.	17.	18.	19.	20.
(C)	(D)	(A)	(A)	(B)	(C)	(D)	(B)	(A)	(B)
21.	22.	23.	24.	25.	26.	27.	28.	29.	30.
(G)	(A)	(D)	(I)	(H)	(F)	(E)	(C)	(B)	(J)
31.	32.	33.	34.	35.	36.	37.	38.	39.	40.
(B)	(A)	(D)	(C)	(C)	(C)	(D)	(D)	(B)	(C)
41.	42.	43.	44.	45.	46.	47.	48.	49.	50.
(A)	(D)	(B)	(B)	(C)	(A)	(A)(C) (D)	見詳解	(C)	(A)

第壹部分、選擇題

一、詞彙題

目標：評量考生對高中常用實詞詞彙 (content words) 的構詞、語意、字詞搭配 (collocation) 的理解與運用能力。

- (D) 難易度：中偏易
解析：考動詞。一位南非企業家幾十年前開始了一個犀牛飼養計畫，並已設法增加犀牛的數量。
(A)承認 (B)膽敢 (C)投降 (D)設法
- (C) 難易度：中偏難
解析：考名詞。在一項探索極端孤立和剝奪對身體和心理健康影響的科學研究中，有一位運動員自願生活在一個 70 公尺深的洞穴中三個禮拜。
(A)居民 (B)敵意 (C)孤立 (D)冷漠
- (B) 難易度：中偏難
解析：考名詞。科學家們發現植物在遭受壓力時會發出聲音，但這些聲音的頻率太高，人耳無法聽到。
(A)基礎 (B)頻率 (C)架構 (D)反饋
- (A) 難易度：中偏易
解析：考副詞。一個研究團隊發現大腦遺忘不再相關的信息對大腦有益，因為這能使大腦運作順暢。
(A)順暢地 (B)粗略地 (C)一般地 (D)主要地
- (C) 難易度：中偏難
解析：考動詞。雖然在春天看著花苞露出細緻的花瓣賞心悅目，但有些人因為伴隨春天而來的季節性過敏例如花粉症，而對於每年這個時期感到害怕。
(A)延伸 (B)削弱 (C)害怕 (D)應得
- (B) 難易度：中偏難
解析：考形容詞。這品種的鳥類已經愈來愈稀少，所以政府打算推出一項新法來保護這些鳥類以免他們瀕臨滅絕。
(A)實際的 (B)少見的 (C)專用的 (D)強烈的
- (D) 難易度：中偏難
解析：考動詞。教師聯盟正敦促政府在 2030 年之前放棄雙語教育政策，因為這個計畫與臺灣的考試導向制度有衝突。
(A)相符 (B)合作 (C)一致 (D)抵觸
- (A) 難易度：中偏易
解析：考名詞。在決定購買之前，Ken 對車子的外觀與內裝做了仔細的檢查，沒有漏掉任何細節。
(A)檢查 (B)介紹 (C)入侵 (D)跡象
- (B) 難易度：中偏易
解析：考副詞。在鋼琴演奏會前一晚，Jane 持續練習鋼琴，一再地彈同一首曲子直到精熟。
(A)共同地 (B)持續地 (C)保守地 (D)始終如一地
- (C) 難易度：中偏易
解析：考名詞。在疫情打斷她每天早上的游泳鍛鍊後，六十多歲的 Lisa 開始練習舉重，而且甚至參加了舉重比賽。
(A)回應 (B)路線 (C)例行公事 (D)渡假勝地

二、綜合測驗

第11.至15.題為題組

進廟拜拜雖然是一件民眾習以為常之事，但還是有不少人對於「怎麼拜」摸不著頭緒。經常是，有門就進，點了香就拜！然而，進廟拜拜是有一些特定的禮儀和規範。

其中之一是遵從「左尊右卑」的原則。從寺廟望出去時，左右兩側的門分別被稱為「龍門」和「虎門」。據信從龍門進入可以借助龍的祥瑞之氣以利參拜者招福避邪。而從虎門離開則是借助老虎令人感到畏懼的意象來抵抗邪惡勢力，同時也象徵著重生。除了仔細注意方位之外，人們還可以留意門旁牆上的裝飾。龍門通常有著吉祥的龍雕塑，而虎門則裝飾有凶猛的老虎圖案。

透過遵守這一習俗並注意象徵性的裝飾，人們可以在虔誠地參與拜拜時，並迎接好運與祝福。畢竟，為了展現虔誠的態度，在參拜寺廟時再謹慎小心也不為過。

目標：評量考生參酌上下文意發展，掌握各類詞彙 (含實詞、虛詞、慣用語及轉折詞等) 及語法應用的能力。

內容：此篇文章主要介紹進廟宇參拜時，龍門進虎門出代表的意義。

- (C) 難易度：中偏易
解析：(A)規則；條例 (B)試驗；審判 (C)禮儀；規矩 (D)調整；適應
此題考單字文意，故選(C)。
- (D) 難易度：中偏難
解析：(A)接管；接手 (B)(尤指因不開心)開始使用不好之物 (C)以...當基礎 (D)使用...以獲得好結果
此題考相關片語的搭配，根據文意據信從龍門進入可以借助龍的祥瑞之氣以招福避邪。
- (A) 難易度：中偏難
解析：此格考非限定形容詞子句改為的分詞片語。
原句為 *Exiting through the Tiger Gate channels the formidable energy of the tiger to suppress malevolent forces, which symbolizes a rebirth or renewal.*
- (A) 難易度：中偏易
解析：(A)裝飾有 (B)由...組成；構成 (C)伴隨著 (D)提供
此題考相關片語的搭配，根據文意虎門上裝飾有凶猛的虎的圖案。
- (B) 難易度：中偏易
解析：(A)為了 (B)有著 (C)藉由 (D)在...裡面
此題考介系詞，根據文意透過遵守這項習俗並注意象徵性的裝飾，我們可以在拜拜時保有一顆虔誠的心。

重要字、詞與片語

worship	v.	敬奉；崇拜
protocol	n.	禮儀；禮節
respectively	adv.	分別
auspicious	v.	吉利的；吉祥的
ward	sth. off	phr. 避開；阻止；擋住
channel	v.	引導；把...導入；將...引入
formidable	adj.	可怕的；令人敬畏的；難對付的
suppress	v.	鎮壓；壓制；制止
malevolent	adj.	惡意的；惡毒的；有害的
renewal	n.	延期；更新；更換
ornamentation	n.	裝飾；點綴

第16.至20.題為題組

每學期學習新課程都是學生面臨的挑戰。許多學生依賴傳統的學習方法，例如反覆學習和重讀筆記或教科書，認為重複閱讀相同的題材是記住資訊的最佳方式。然而，研究表明，更有效的方法來實現資訊的長期記憶以及成功的資訊檢索。

增進資訊記憶和檢索效能的最有效學習策略之一是「提取練習 (retrieval practice)」。提取練習包括從記憶中積極的回憶資訊，在此同時不參考課程資料，接著進行後續的準確性檢查。準確性檢查必須在積極回憶後才能進行，如此才能有助於學生找出他們需要改進的地方。提取練習的實施方式有：製作練習題或是

閃卡 (flashcards)、遮蔽授課投影片並回想相關訊息、或是專注於考試中可能出現的問題類型。藉由將提取練習融入學習例程序，學生可以大幅提高他們的考試表現和對課程內容的長期記憶。

然而，許多學生覺得提取練習令他們感到不舒服和太有挑戰性。他們可能會覺得當自己回答錯誤時，表示自己沒有學到相關材料。相反地，當他們重複閱讀材料時，會產生一種錯覺：誤認自己已精熟學習內容。為了改變這種情況，老師必須不斷提醒學生：重複閱讀並不涉及考試所需的認知過程，而提取練習則強化了與所學知識相關聯的神經通路，從而幫助學習者產生更持久的記憶。

內容：本文討論了傳統的學習方法（如反覆學習）的侷限性，提取練習 (retrieval practice) 的有效性，以及學生在採用這種策略時面臨的挑戰。

16. (C) 難易度：中
解析：(A)編造 (B)寫下 (C)依靠 (D)撥快
此格考動詞片語，根據前後文文意，最適合的語意是：「依靠」，故選(C)。
17. (D) 難易度：難
解析：(A)同時的 (B)在前的 (C)引起混亂的 (D)接著的
此格考形容詞，根據後文文意「準確性檢查必須在積極回憶後才能進行」，最適合的語意是：「接著的」，故選(D)。
18. (B) 難易度：難
解析：(A)推翻 (B)使用 (C)監管 (D)規定
此格考動詞，根據前後文文意，此句的意思是學生可以使用下列所述的提取練習方法，最適合的語意是：「使用」，故選(B)。
19. (A) 難易度：難
解析：(A)錯覺 (B)意識形態 (C)詐欺 (D)症狀
此格考名詞，根據前後文文意，最適合的語意是：「錯覺」，故選(A)。
20. (B) 難易度：中偏易
解析：(A)是否 (B)然而 (C)除非 (D)因為
此格考連接詞，根據前後文文意，最適合的語意是：「然而」，故選(B)。

重要字、詞與片語

repetitive *adj.* 重複的 retain *v.* 保留 indicate *v.* 指出
retention *n.* 保留 retrieval *n.* 提取 consult *v.* 參照
accuracy *n.* 準確度 flashcard *n.* (教學用)閃卡
incorporate *v.* 將...包含在內 cognitive *adj.* 認知的
neural *adj.* 神經系統的 pathway *n.* 通路 permanent *adj.* 永久的

三、文意選填

第21.至30.題為題組

椒鹽捲餅是人們數百年來一直很喜歡的甜味或鹹味的糕點。雖然原本的椒鹽捲餅是扭結狀的，但現在它們有各式各樣的形狀和口感。有些吃起來鬆軟，而有些則像蘇打餅乾一樣硬硬脆脆的。一般認為椒鹽捲餅源自於西元 610 年。當時，一位義大利修道士創造了 pretiola 來激勵他的學生更努力。他把麵包麵糰捲成長繩狀，然後盤繞成兩個環。對這名修道士來說，pretiola 看起來就像是雙手交叉在胸前祈禱。pretiola 的製作原料很簡單，如麵粉、鹽和水，因此，它成為大齋期那個月很適合的食物。那時候肉、乳製品和雞蛋都被嚴格禁止。也因為如此，它們開始流行並且傳到歐洲各地，最後來到了德國，在那裡 pretiola 演化成我們現在所知的 pretzels (椒鹽捲餅)。德國移民在 18 世紀時又將椒鹽捲餅帶到了賓州，而椒鹽捲餅自此征服了全世界。如今，全球的椒鹽捲餅市場產值將近五億美元！

椒鹽捲餅在歐洲部分地區被視為好運的象徵。以前德國兒童會在新年那天配戴椒鹽捲餅的項鍊。而對瑞士人來說，椒鹽捲餅相連的環象徵永恆的愛情，而這個象徵就是片語 tying the knot (結婚) 的由來。

近來，椒鹽捲餅有千奇百樣的口味。它們可以是鹹的、沾巧克力、上面加堅果和種子，或是和起士醬一起食用。也可發現它們有許多形狀——從棒形的到心型的椒鹽捲餅都有。有些甚至像字母！椒鹽捲餅從不起眼的義大利起源確實已大有進展。所以，不要自尋煩惱了，趕緊拿些椒鹽捲餅大快朵頤一番吧！

目標：評量考生依據篇章段落的文意發展，掌握實詞詞彙運用的能力。

內容：本文談椒鹽捲餅的由來以及演變。

詞彙選項：

(A)鼓勵	(B)抹醬	(C)永恆的	(D)交叉	(E)接管；征服
(F)高漲	(G)質地	(H)適合的	(I)成分	(J)相似

21. (G) 難易度：中偏難
解析：此句要求填入名詞。根據下一句：椒鹽捲餅有些嘗起來鬆軟，而有些則像蘇打餅乾一樣硬硬脆脆的，故選(G)。
22. (A) 難易度：易
解析：此句要求填入動詞。根據空格後 to study harder，可由前後文語意以及動詞用法推測出答案，故選(A)。
23. (D) 難易度：中偏難
解析：此句要求填入動詞。根據空格後 in prayer over the chest，可推測是在說明祈禱的動作，根據動詞用法推測出答案，故選(D)。
24. (I) 難易度：易
解析：此句要求填入名詞。根據空格後 flour, salt, and water 可推測出答案，故選(I)。
25. (H) 難易度：易
解析：此句要求填入形容詞。根據空格後 during the month of Lent, when meat, dairy, and eggs were strictly forbidden，可推測出答案，故選(H)。
26. (F) 難易度：中偏難
解析：此句要求填入動詞。根據前一句因為成分簡單可在大齋節食用，以及下一句 they spread throughout Europe 傳到歐洲各地，可推測出答案，故選(F)。
27. (E) 難易度：中偏難
解析：此句要求填入動詞。此題考 take over 此片語，且根據下一句 Today, the worldwide pretzel industry has a value of nearly US\$500 million! (如今，全球的椒鹽捲餅市場產值將近五億美元)，可推測出答案，故選(E)。
28. (C) 難易度：中偏易
解析：此句要求填入形容詞。可從空格後的 love 此字以及下一句 This symbol is the source of the phrase "tying the knot." (這個象徵就是片語 tying the knot 的由來)，推測出答案，故選(C)。
29. (B) 難易度：中
解析：此句要求填入名詞。可從前一句 pretzels are available in an extensive range of flavors 以及空格前 They can be salted, dipped in chocolate, topped with nuts and seeds 推測出要選擇與口味有關的答案，故選(B)。
30. (J) 難易度：中
解析：此句要求填入動詞。可從前一句 ranging from pretzel sticks to heart-shaped pretzels 推測出答案，故選(J)。

重要字、詞與片語

pastry *n.* 糕點 array *n.* 一系列
fluffy *adj.* 蓬鬆的
monk *n.* 修道士
Lent *n.* (基督教的)大齋節
Pennsylvanian *n.* 賓州 (位於美國東北部，首都為哈里斯堡，最大城市為費城)
multitude *n.* 許多

四、篇章結構

第31.至34.題為題組

生命的本質一直是在文學和藝術中受到歡迎討論的主題。

31. (B)這在桑頓·懷爾德非常著名的戲劇作品《我們的小鎮》中也一樣。設在一個名為 Grover's Corners 的虛構小鎮，這齣戲帶領觀眾看見 Gibbs 和 Webb 家族，這個小鎮的居民，在 12 年的光陰流逝中的生命片段。

在這齣戲的一開始，懷爾德描述了這些角色的童年時光與單純和源於青春的與無限可能。觀眾見證了年輕的 George Gibbs 和

Emily Webb 的夢想、希望和野心。32. (A)他們的互動充滿了成功的希望和剛萌芽的戀愛氛圍。然而，隨著這齣戲的發展，懷爾德有技巧地描述了大人生活的現實和伴隨而來的挑戰。觀眾經歷了這些角色的婚姻、日常生活的壓力以及年輕理想的逐漸磨損。

懷爾德也呈現了一個令人難忘的死後生活的描述。在這齣戲的最後一幕，在生產她和 George 的第二個孩子時死亡的 Emily 得到了一個重新回到她人生中一天的機會。33. (D)看著她深愛的人們，她注意到她父母的年輕和美麗，並且感覺既懷念、又感激過往的日常生活。但是，不久之後，她在情感上變得難以承受，因為她發現那些還活著的人們並沒有意識到當下的美麗和重要。她忍不住問了，「有任何人在他們還活著的時候就了解到生命的意義嗎，每一分每一秒？」

34. (C)在《我們的小鎮》這個作品裡，懷爾德一再強調了生命的轉瞬即逝的本質。從第一幕，當角色們的希望和夢想以年輕的熱情所呈現，到令人感到酸楚的最後一刻，這個劇作家傳達了一個訊息：我們在地球上的時間是有限的，所以我們必須要活出充實的人生，並擁抱每一個短暫的時刻。

目標：評量考生掌握篇章的組織架構與理解文意脈絡的能力。

內容：本文介紹我們的小鎮這個戲劇作品對生命意義的反思。

難易度：中

重要字、詞與片語

passage <i>n.</i>	(時間的) 流逝
promise <i>n.</i>	(成功的) 跡象
budding <i>adj.</i>	開始發展的
portray <i>v.</i>	描述
strain <i>n.</i>	壓力
erosion <i>n.</i>	磨損
haunting <i>adj.</i>	讓人難忘的
depiction <i>n.</i>	描繪
act <i>n.</i>	(戲劇的) 幕
nostalgic <i>adj.</i>	懷舊的
overwhelm <i>v.</i>	(強烈的感情) 滿溢，使難以承受
transient <i>adj.</i>	轉瞬即逝的
enthusiasm <i>n.</i>	熱情
poignant <i>adj.</i>	令人感到酸楚的
impart <i>v.</i>	傳達
fleeting <i>adj.</i>	短暫的

五、閱讀測驗

第35至38題為題組

自從在 19 世紀末問世以來，自動販賣機已經歷了顯著的演進。最初只需要一個便士便可操作的這些機器主要是以銷售香菸、花生和小飾品等物品為主。如今，我們紀念著自動販賣機的起源，並回顧這項技術在過去 100 年中在美國的非凡旅程。

根據凱瑞·西格雷夫的《自動販賣機：美國社會史》，第一項自動販賣裝置的專利於 1857 年在英國申請通過。有趣的是，該專利是用於發放郵票的機器，而不是食物。不久之後，自動販賣機的概念便跨越大西洋傳入美國。1888 年，Tutti-Frutti 品牌的口香糖自動販賣機在紐約的火車站首次亮相，並迅速受到歡迎。最終導致 18 家主要自動販賣機公司於 1911 年合併為 Autosales Gum 大公司。

在 1930 年代，冷飲自動販賣機被引進，其後在二戰前出現了能夠保持涼爽溫度的電動販賣機。到了 1940 年代，汽水販賣機提供了顧客更多的選項，但其中一種選項依舊難以企及：咖啡。在自動販賣機中生產咖啡對整個行業來說是一大挑戰，直到 1940 年代末才開發出一種能夠自動混合液體咖啡濃縮液和熱水的機器。在 1960 年代，製造商們找到了解決方案，推出了使用研磨烘焙咖啡豆的「咖啡膠囊」的單杯咖啡機，並成功克服了長期以來的障礙。

在 21 世紀初，自動販賣機開始融入先進技術。例如，2004 年，國際飲料和零食公司蒙德里茲引入了一種具有突破性的 3D 列印機，根據 Twitter 上的「熱門口味」訂制奧利奧餅乾。國家自動販賣協會預測自動販賣機在未來的進展，如臉部識別軟件和互動式觸控式螢幕將增進個性化的消費體驗。自動販賣機在過去一個半世紀取得的重大進展之下，不禁令人期待在未來還會為我們帶來什麼樣的改變。

目標：評量考生綜合運用詞彙（含慣用語）、語意、語法、語用以及篇章結構的知識，理解文意脈絡、擷取文章重要訊息，並加以分析、比較與推理的能力。

內容：此篇文章主要在介紹自動販賣機在美國近 100 年來的演進與改變。

35. (C) 難易度：中偏易

解析：這篇文章是如何組織架構的？

- (A)以因果關係為基礎
- (B)按重要性的順序
- (C)按時間的順序
- (D)按分類方式

36. (C) 難易度：中偏難

解析：以下哪一詞彙的意思與第三段中的單詞 *elusive* 最為相近？

- (A)無效果的
- (B)贊同的；討人喜歡的；有利的
- (C)難獲得的
- (D)有希望的；有前途的

37. (D) 難易度：中偏易

解析：根據本文，下列何者不是正確的？

- (A)第一臺在英國獲得專利的自動販賣機並非是為了販售食物所設計的。
- (B)在 1910 年代左右，為了跟上口香糖自動販賣機的趨勢，許多公司選擇合作以滿足市場需求。
- (C)在 1930 年代以前，讓自動販賣機裡的飲料保持在一定的低溫是有難度的。
- (D)在 1960 年代，相較於咖啡豆，咖啡膠囊更受到咖啡自動販賣製造商的愛戴。

38. (D) 難易度：中偏難

解析：從此篇文章中可以推斷出什麼？

- (A)蒙德里茲在未來依舊會在科技結合販賣機的市場上占領主導地位。
- (B)在科技結合的自動販賣機應用中，產品的標準化將成為關注的重點。
- (C)3D 列印技術在智能販賣機的應用上將大幅改善產品的品質。
- (D)面部辨識的 AR 技術將被應用在智能販賣機，以增進消費者的體驗。

重要字、詞與片語

predominantly <i>adv.</i>	占主導地位地；占絕大多數地；顯著
commemorate <i>v.</i>	紀念；緬懷
patent <i>n./v.</i>	專利權；申請專利
dispense <i>v.</i>	分發；提供；供應
debut <i>n./v.</i>	首演；首次登臺；首次亮相
consolidation <i>n.</i>	鞏固；合併；聯合
colossal <i>adj.</i>	巨大的；龐大的
concentrate <i>n.</i>	濃縮物；濃縮液

第39至42題為題組

愈來愈多零售商使用人工智能 (AI) 來改善其業務運營。AI 被用來追蹤產品的市場價格，AI 也根據供應和物流的變化，調整商店中成千上萬件產品的價格。它可以預測降價的理想時間，使零售商獲得最大的利潤。此外，零售商還使用 AI 來管理員工的工作時間表，AI 也透過電腦視覺技術，使商品能自動結帳，AI 也能在網路上向客戶推薦產品。

沃爾瑪旗下的山姆會員商店最近推出了一款自動掃地機器人，它使用電腦視覺技術來檢測缺貨、庫存不足或標籤錯誤的商品。這些訊息將被傳回一個系統（平臺），該系統可能會改變員工工作時的優先順序。零售商還在其名為 Ask Sam 的虛擬語音助手中使用 AI，工人可以使用它來查找價格、定位物品或幫助客戶。在未來，AI 可能會確定工人應該烤多少可頌，並在甜甜圈的數量不足時發出提醒。

然而，搭載人工智慧的系統並不總是受到歡迎。當沃爾瑪引進機器人清潔工時，店員抱怨機器人常常故障，而且訓練它們需要花費很長的時間。臉部識別系統一直以來常常有缺陷，經常誤認有色人種，這可能導致安全機制不公正地針對棕色和黑色人種。

AI 的採用將對零售業的就業產生影響。員工的工作很可能會被機器支配，由機器認定最重要的事情而決定。員工可能需要適應與數據和技術一起工作。AI 也可能意味著更多的風險，例如演算法造成的歧視或不同類型客戶受到的負面影響。

總體而言，AI 將提高員工生產力，為客戶減少各種不便。零售商在使用 AI 時需要謹慎，以確保它是一種好的力量。

內容：本文討論了 AI 在零售產業的應用，它帶來了好處以及潛在的風險。

39. (B) 難易度：中
 解析：作者撰寫這篇文章的主要目的是什麼？
 (A)討論零售技術的歷史。
 (B)討論人工智慧對零售業的影響。
 (C)強調在零售業使用人工智慧的風險。
 (D)提供有關如何在零售企業實施人工智慧的指南。
40. (C) 難易度：中
 解析：Sam's Club 如何在其業務中使用人工智慧？
 (A)監控員工生產力。
 (B)決定店鋪佈局和設計。
 (C)協助價格和商品查詢。
 (D)提供虛擬實境的購物體驗。
41. (A) 難易度：中
 解析：根據本文，在零售業中使用 AI，可能存在的風險是什麼？
 (A)對個人展現偏見。
 (B)沒有準確地加總物品的價格。
 (C)結帳緩慢而導致大排長龍。
 (D)降低勞動力生產力。
42. (D) 難易度：中偏難
 解析：ecosystem 這個字在第二段的意思是什麼？
 (A)一個動植物共生互動的場所。
 (B)一個旨在增加品牌知名度的行銷活動。
 (C)一種用來管理財務的軟體程式。
 (D)一種相互連接的科技系統，用於支援特定目標。

重要字、詞與片語

retailer *n.* 零售商
 artificial intelligence (AI) *n.* 人工智慧
 logistics *n.* 物流 forecast *v.* 預測 maximize *v.* 使...最大化
 automated *adj.* 自動化的 autonomous *adj.* 自動的
 stock *n.* 庫存 mislabeled *adj.* 標示錯誤的
 ecosystem *n.* 生態系統 priority *n.* 優先
 virtual *adj.* 虛擬的 locate *v.* 定位
 well-received *adj.* 受歡迎的 associate *n.* 生意夥伴
 malfunction *n.* 故障 flaw *n.* 缺陷
 misidentify *v.* 誤認 target *v.* 針對
 dictate *v.* 下令、規定 deem *v.* 認為
 algorithmic *adj.* 算法的 discrimination *n.* 歧視
 adverse *adj.* 不利的 implementation *n.* 實施

第43.至46.題為題組

抹香鯨是深海中最大的巨人。作為地球上最大的有牙齒的捕食性動物，他們以獨特的外觀為人所知——一個占據他們身長四分之一至三分之一的巨大且直邊的前額、一個相較而言較小且包含著圓錐狀牙齒的下顎和一個位於他們巨大的頭的左前方的噴氣孔。

抹香鯨在 18 世紀得到他們的名字。在那段時間，捕鯨者有一個重大的發現：抹香鯨的頭包含了一個充滿著白色液體的巨大器官。這些捕鯨者誤把這些液體當成是這種鯨魚的精液 (sperm)，因此命名這個物種為「精液鯨魚」(sperm whale)。

這種白色液體是鯨蠟，用於幫助這種鯨魚透過聲音進行迴聲定位。然而，也是它的存在導致抹香鯨的苦難。因為鯨蠟在油燈、潤滑油和蠟燭上應用的珍貴價值，從 1800 到 1987 年，抹香鯨被捕鯨業不間斷地追捕。數千隻抹香鯨被獵捕，幾乎毀滅了所有抹香鯨的數量。直到國際捕鯨委員會實施了捕獵中止期，抹香鯨才終於從這樣的剝削中得到保護。

儘管獵鯨已經不再是一個主要的威脅，抹香鯨現在面臨到另一個來自人類活動的威脅——被捕魚裝置纏住。一旦抹香鯨被捕魚裝置纏住，它可能會拖著附著的裝置游泳很長的距離，導致它的疲勞與壓力。在較壞的情況下，這樣的糾纏嚴重地限制抹香鯨活動的自由性，這可能會阻礙牠潛水和捕捉食物的能力，導致營養不良與體重減輕。在最糟的情況，這可能造成抹香鯨無法移動至水平面呼吸。因此，牠可能就溺死了。

內容：本文文章重點在抹香鯨的介紹與其過去與現在所面臨到的威脅。

43. (B) 難易度：中偏易
 解析：文章中討論了抹香鯨的哪些方面？
 (A)外貌→名字→發聲→壽命
 (B)外貌→名字→苦難→目前的挑戰
 (C)棲息地→名字→苦難→壽命
 (D)棲息地→名字→發聲→目前的挑戰
44. (B) 難易度：中
 解析：根據文章，以下哪一個關於抹香鯨的敘述是正確的？
 (A)他們對周遭環境的導航能力是 19 世紀一個重要的發現。
 (B)他們曾是商業捕鯨業的主要目標。
 (C)他們的頭部含有珍貴的鯨蠟是一個錯誤的觀念。
 (D)他們是因為他們獨特的外貌特徵而被發現。
45. (C) 難易度：中偏易
 解析：下面哪一張圖最接近抹香鯨的形象？
 第一段提到抹香鯨「有著直邊的前額、前額約占據身體大小三分之一至四分之一；相比額頭，下顎較小，並且有圓錐狀的牙齒，在頭的左前方有一個噴氣孔」，故答案選(C)。
46. (A) 難易度：中偏易
 解析：以下哪一個選項和最後一段所出現的「entangled」在字意上最相近？
 (A)被捆綁 (B)被拒絕
 (C)被帶進來 (D)被快速翻動

重要字、詞與片語

distinctive *adj.* 獨特的 block *n.* 有著直邊的硬物
 make up *v.* 構成 relatively *adv.* 相對而言 jaw *n.* 下顎
 cone *n.* 圓錐體 blowhole *n.* 噴水孔 derive *v.* 從...中獲得
 fluid *n.* 液體 presence *n.* 存在
 relentlessly *adv.* 持續地 implement *v.* 實施
 moratorium *n.* 中止 exploitation *n.* 剝削
 entanglement *n.* 糾纏 gear *n.* 裝備
 hinder *v.* 阻礙 malnutrition *n.* 營養不良

第貳部分、混合題

第47.至50.題為題組

大約 12,000 年前，隨著穩定的農業社區的興起，人類開始積極大量地利用自然資源。然而，最近一系列的災害，從新冠肺炎到美國一個世紀以來最嚴重的野火，明確地顯示人類活動似乎已太過。我們對自然界的干預使得這些人類活動更容易演變成悲劇。我們創造了「人類世」，而現在我們正見證「人類世」的負面結果。

所以，到底什麼是「人類世」？「人類世」是一個以人類活動對地球生態系統的深遠影響為特徵的時代，它標誌著人類與自然之間關係的典範轉移。這個術語在 2000 年由諾貝爾獎得主 Paul Crutzen 提出，它結合了希臘詞「anthropos」(人類)和「-cene」(地質時代的標誌)。Crutzen 相信，人類作為地球照顧者，背負了巨大的責任。他認為現在正是時候以改名來反思人類角色。2007 年，他進一步指出「巨大加速」，指的是自 20 世紀中葉以來人類對地球的不斷增強的影響。

為了加強人類是地球主要的傷害來源這個概念，在 Crutzen 首次提到這個術語的幾個月後，他和美國生物學家 Eugene Stoermer 在一篇出自國際地球圈層——生物圈計畫的通訊中的第 17 頁關於「人類世」的文章中進一步展開了這個想法。他們強力主張人類已進入我們星球歷史上一個前所未有的階段，在這個階段中，人類已經成為星球變化的主要推動力量。根據他們：「除非發生類似小行星撞擊或核戰爭這樣的重大災難，否則人類將在許多千年內成為一個重大的地質力量。」在那時，這個發人深省的術語會帶來的影響似乎仍舊被低估。然而，這個概念卻開始傳播起來。來自不同領域的學者開始提供關於「人類世」的不同觀點。地質學家通過研究地層證據來確定這個時代的地質標誌。生態學家研究人類行為的生態後果，如生物多樣性的流失和氣候變遷。社會科學家深入研究推動這些變革的社會經濟因素，而哲學家則反思我們作為地球管理者的道德和倫理層面。

總之，「人類世」的概念證明了我們的地球對人類活動的敏感性。它強調了跨學科合作解決這個時代所帶來的多方面挑戰的迫切需要。我們必須體認到我們的責任，努力追求可持續的實踐、環境管理和與地球生態系統保育相協調的方法。只有通過集體行動，我們才能為我們共享的地球上所有生命鍛造出一條更具彈性和和諧的未來之路。

目標：本大題旨在評量考生綜合運用詞彙（含慣用語）、語意、語法、語用以及篇章結構的知識，理解文意內容並擷取重要訊息加以分析、比較與推理，且能根據提示做出適當的表達或回應。

內容：人類世及其命名來由、學術界反應之介紹。

47. (A)(C)(D) 難易度：難

解析：如文章所述，人類是人類世的創造者，然而現在我們正在承擔我們自己創造的後果。這篇文章中提到的負面後果有哪些？

(A)此選項為「野火 wildfire」之定義：在林地或野外地區迅速且無法控制地蔓延的不受控火災。

(B)此選項為「過度旅遊 overtourism」之定義：一個受歡迎的旅遊目的地因過多遊客而不堪重負的情況。

(C)此選項為「生物多樣性流失 biodiversity loss」之定義：物種在特定棲息地或全球範圍內多樣性和豐富度的下降。

(D)此選項為「大流行病 pandemic」之定義：影響多個國家或大陸上大量人口的全球性疾病爆發。

(E)此選項為「男女性別比例不均 gender imbalance」之定義：在特定背景下（如人口、勞動力市場或社會環境）性別間個體的不平等分布或不相稱。

(F)此選項為「經濟蕭條 recession」之定義：經濟活動在多個經濟環節中顯著下降的經濟衰退或收縮。

選項(A)「野火」與(D)「大流行病」在文章第一段被提及；(C)「生物多樣性流失」在第三段被提及。其餘選項未被文章提及。

48. (1) sustainable；(2) preserve 難易度：難

解析：此題改寫自文章最後一段，根據文意，我們必須體認到我們的責任，努力追求可持續的實踐、環境管理和與地球生態系統保育相協調的方法，對應到文中 Recognizing our responsibility, we must strive for sustainability, environmental stewardship, and holistic approaches that harmonize human progress with the preservation of Earth's ecosystems. 第一格以 sustainable practices 代換 sustainability，故第一格為「sustainable 持續的；永續的」。... embrace holistic approaches that safeguard and _____ Earth's ecosystems while promoting human progress. 對應到文章 ... holistic approaches that harmonize human progress with the preservation of Earth's ecosystems.，故第二格對應 preservation，惟須配合上下文更改為動詞 preserve。

評分原則：每小題 2 分，各小題須全對才給分，共 4 分。

49. (C) 難易度：中偏易

解析：原句文意為「然而，這個概念卻開始傳播起來」，選項中只有(C)選項「soared」適合搭配主詞 the concept，表「概念傳播開來」。(A)選項表「自願做...」；(B)選項表「下降；減少」；(D)選項表「潛水」。

50. (A) 難易度：中偏難

解析：下列哪個敘述最符合「人類世」的定義？

(A)一種地質年代，其特徵為人類活動對地球生態系統的影響。

(B)一種促進各領域合作和技術進步的現象。

(C)一種由小行星撞擊或核戰引起的災難事件。

(D)一篇由 Paul Crutzen 和 Eugene Stoermer 撰寫的新聞通訊文章。

根據文章第二段內容，人類世是一個以人類活動對地球生態系統的深遠影響為特徵的時代，故答案應為(A)。

重要字、詞與片語

epoch *n.* 時代，紀元

laureate *n.* 得獎者，獲得桂冠的人 acceleration *n.* 加速

catastrophe *n.* 大災難 asteroid *n.* 小行星

stratigraphic *adj.* 地層的，地層學的 steward *n.* 管理者

testament *n.* 證明 holistic *adj.* 全面的

resilient *adj.* 有彈性的；適應性強的

第參部分、非選擇題

一、中譯英

1. In response to issues of // global warming and serious air pollution, // countries worldwide have announced // their goals of energy conservation recently.

2. To meet the demand // for energy conservation, // all car manufacturers are dedicated to // the development of electric vehicles / cars.

評分原則：

1. 本大題總分 8 分，每小題滿分 4 分。

2. 每個錯誤扣 0.5 分，各部分獨立，扣完為止。

3. 相同之拼字錯誤，只扣一次。

4. 句首未大寫或標點符號不妥，各扣 0.5 分，只扣一次。

二、英文作文

In the fast-paced society, more and more people choose to go outdoors on weekends or holidays, because they can get a short break from their daily routine and tight schedule. These two kinds of destinations offer people with totally different experiences. Picture A depicts an amusement park featuring multiple thrilling rides that are definitely suited to entertain visitors of all ages. On the one hand, there are classic rides like the Ferris wheels and carousel that are perfect for younger children. On the other hand, more thrilling rides like roller coasters and spinning rides are sure to satisfy the demands of older thrill seekers. Picture B shows a peaceful and relaxing scene of a picnic under beautiful cherry blossoms. Imagine sitting on a blanket on the lawn and basking in warm sunshine. What a tranquil moment it is! On top of that, the picnic basket, filled with tasty food, adds to the joy of the serene scene.

Personally, I would prefer to have a picnic under cherry blossoms with my family or friends. As a nature lover, nothing pleases me more than to indulge myself in the beauty of nature. I can feast my eyes on the flowers in bloom, watching butterflies fluttering from one to another, as the sweet fragrance of the flowers greets my nostrils. The cozy breeze also brushes against my skin with the lush green leaves rustling gently. Meanwhile, listening to the birds chirping, I can enjoy the calming atmosphere to the fullest. Next, sitting under trees filled with beautiful flowers while enjoying delicious food not only relieves my pressure but also refreshes me. Above all, it is a fantastic moment when friends or family members sitting around on a blanket spend time catching up with each other. There is no doubt that such a delightful picnic experience provides me with a good outlet for the hustle and bustle of everyday life.

評分原則：本大題總分 20 分，採整體式評分，分為五等級：特優（19~20 分）、優（15~18 分）、可（10~14 分）、差（5~9 分）、劣（0~4 分），閱卷委員於閱讀完考生試卷後，初步決定一個分數，再以各分項評分標準（詳見下表）檢閱是否符合此分數。另外，字數明顯不足，扣 1 分。未分段，扣 1 分；寫多段，不扣分。

英文作文評分指標

等級 項目	優	可	差	劣
內容	主題(句)清楚切題,並有具體、完整的相關細節支持。 (5~4分)	主題不夠清楚或突顯,部分相關敘述發展不全。 (3分)	主題不明,大部分相關敘述發展不全或與主題無關。 (2~1分)	文不對題或沒有寫(凡文不對題或沒寫者,其他各均以零分計篇)。 (0分)
組織	重點分明,有開頭、發展、結尾,前後連貫,轉承語使用得當。 (5~4分)	重點安排不妥,前後發展比例與轉承語使用欠妥。 (3分)	重點不明,前後不連貫。 (2~1分)	全文毫無組織或未按提示寫作。 (0分)
文法、句構	全文幾無文法、格式、標點錯誤,文句結構富變化。 (5~4分)	文法、格式、標點錯誤少且未影響文意之表達。 (3分)	文法、格式、標點錯誤多且明顯影響文意之表達。 (2~1分)	全文文法錯誤嚴重,導致文意不明。 (0分)
字彙、拼字	用字精確、得宜,且幾無拼字、大小寫錯誤。 (5~4分)	字詞單調、重複,用字偶有不當,少許拼字、大小寫錯誤,但不影響文意之表達。 (3分)	用字、拼字、大小寫錯誤多,明顯影響文意之表達。 (2~1分)	只寫出或抄襲凹題意有關的零碎字詞。 (0分)

臺北區 112 學年度第一學期

學科能力測驗模擬考試

英文考科

請於考試開始鈴響起，在答題卷簽名欄位以正楷簽全名

—作答注意事項—

考試範圍：第 1 ~ 5 冊

考試時間：100 分鐘

作答方式：

- 選擇題用 2B 鉛筆在「答題卷」上作答；更正時以橡皮擦擦拭，切勿使用修正帶（液）。
- 除題目另有規定外，非選擇題用筆尖較粗之黑色墨水的筆在「答題卷」上作答；更正時，可以使用修正帶（液）。
- 考生須依上述規定劃記或作答，若未依規定而導致答案難以辨識或評閱時，恐將影響成績。
- 答題卷每人一張，不得要求增補。

選擇題計分方式：

- 單選題：每題有 n 個選項，其中只有一個是正確或最適當的選項。各題答對者，得該題的分數；答錯、未作答或劃記多於一個選項者，該題以零分計算。
- 多選題：每題有 n 個選項，其中至少有一個是正確的選項。各題之選項獨立判定，所有選項均答對者，得該題全部的分數；答錯 k 個選項者，得該題 $\frac{n-2k}{n}$ 的分數；但得分低於零分或所有選項均未作答者，該題以零分計算。

祝考試順利



版權所有·翻印必究

第壹部分、選擇題（占 62 分）

一、詞彙題（占 10 分）

說明：第 1. 題至第 10. 題為單選題，每題 1 分。

1. It is necessary for construction companies to _____ their building plans to the city council for approval.
(A) submit (B) secure (C) steer (D) sustain
2. There was _____ evidence showing that this man was guilty, so he was eventually arrested and put in jail.
(A) delicate (B) hollow (C) mechanical (D) abundant
3. The manager has no _____ for improper behavior in the workplace, and holds his staff members accountable for their own actions.
(A) hesitation (B) tolerance (C) collaboration (D) distinction
4. The train stopped _____ without warning, causing quite a few passengers to fall off their seats.
(A) initially (B) consciously (C) abruptly (D) precisely
5. No country can accept any attempts by other nations to _____ in its domestic affairs and manipulate its elections.
(A) modify (B) interfere (C) endeavor (D) resemble
6. We should avoid using cellphones in dim light for too long, which could cause _____ eye damage that cannot be reversed.
(A) efficient (B) reckless (C) permanent (D) compulsory
7. Jacob has an uncontrollable _____ about cleanliness and cannot stand anyone messing up the house.
(A) obsession (B) catastrophe (C) fertilizer (D) convention
8. The company was accused of _____ against a female employee, who received unequal pay for the same work done by her male colleagues.
(A) discriminating (B) campaigning (C) negotiating (D) prohibiting
9. The organization operates _____ for charitable purposes. All its efforts are directed toward helping people in need.
(A) automatically (B) swiftly (C) furiously (D) exclusively
10. During the COVID-19 pandemic, people were required to observe necessary _____ against the virus to stay safe and keep it from spreading.
(A) circulations (B) precautions (C) obligations (D) commitments

二、綜合測驗（占 10 分）

說明：第 11. 題至第 20. 題為單選題，每題 1 分。

第11.至15.題為題組

When Koko, the celebrated western lowland gorilla, was about twelve months old, animal psychologist Francine Patterson started to train her to communicate through sign language. Before her death at age 46, she had learned an incredibly large number of words, according to Koko's instructors. Patterson and her team documented that Koko was able to use some 2,000 words to convey thoughts and feelings. 11., some scientists questioned Patterson's methods. They also debated how much of Koko's communication actually came from herself and how much of it was interpreted by humans 12. their own thoughts or emotions onto her.

One of those skeptical scientists was Prof. Graham Turner of Heriot-Watt University. He acknowledged that the serious efforts to teach apes some signing began in the 1960s. And with researchers 13. to teach individual signs derived from American Sign Language, the apes did learn to perform some hand gestures. However, considering the complexity of the ASL system, Turner argued that it was a distortion to imply that Koko or any ape had 14. acquired the ability to use sign language like a human being.

15. Koko had learned the supposed language skills, her command of gestures was extraordinary for a gorilla. The story of Koko the gorilla will keep inspiring researchers in many fields.

11. (A) Similarly (B) Besides (C) Nevertheless (D) Therefore
 12. (A) transferring (B) projecting (C) meditating (D) indicating
 13. (A) attempt (B) attempted (C) attempting (D) to attempt
 14. (A) genuinely (B) radically (C) preferably (D) inevitably
 15. (A) As long as (B) Even though (C) If only (D) Whether or not

第16.至20.題為題組

In social psychology, an "ingroup" is a group to which someone belongs, and an "outgroup" is a group to which the person does not belong. When it comes to attitudes and personality traits, people tend to see their ingroup members as different while they view outgroup people as 16.. The phenomenon that influences people's perception of individuals from outgroups is known as the "outgroup homogeneity effect."

Research has found that there are a variety of factors that 17. the "outgroup homogeneity effect." One obvious fact is that people usually contact individuals from their own group, increasing their understanding of the differences among their ingroup members. People also tend to organize and recall information about ingroups in terms of individual uniqueness 18. generalized characteristics. Furthermore, people are often driven to make distinctions among ingroup members with whom they will have future contact. This motivation is seldom extended to outgroup members, 19.. When these factors operate together, the end result is often an ingroup that appears to have a diverse assortment of individuals, and an outgroup 20. people appear similar to each other.

Since this bias can cause people to make false assumptions of outgroups, it is important for us to try to better understand people from different groups and show greater acceptance toward them.

16. (A) agreeable (B) identical (C) superior (D) generous
 17. (A) contribute to (B) engage in (C) depend on (D) stem from
 18. (A) along with (B) based on (C) regardless of (D) rather than
 19. (A) either (B) instead (C) though (D) likewise
 20. (A) which (B) where (C) while (D) what

三、文意選填（占 10 分）

說明：第21.題至第30.題為單選題，每題 1 分。

第21.至30.題為題組

Prague, the capital city of the Czech Republic, is one of the most magical cities in Europe. It is 21. with character, from its curious backstreets to peculiar old-school theaters. The great 22. of this charming city draws visitors from across the globe, making it one of the most popular destinations in the world.

Spanning the Vltava River with sixteen pillars, Charles Bridge is an attraction that is sure to 23. the mind of any traveler planning a trip to Prague. In the past, this iconic bridge connected Prague's Old Town to Prague Castle, making a huge and 24. impact on the city's cultural landscape. When viewed from a distance, the bridge presents itself in all its splendor, offering visitors the 25. to capture its beauty with a camera or a phone. The best way to explore Charles Bridge, however, is by walking on the bridge at a slow and 26. pace. There are thirty statues arranged in two rows on the bridge—one on each side. While strolling on the bridge, tourists can 27. the exquisite details of these art pieces, each being a visual delight.

Another must-visit attraction is Prague Castle, the largest castle in the world. It is a castle complex with various awe-inspiring buildings, including St. Vitus Cathedral. This holy 28. is the dominant feature of Prague Castle, demanding attention with its striking Gothic architecture. Founded in 880 as a seat of power for the Bohemian kings, Prague Castle remains the official 29. of Czech presidents today. Given its architectural value and 30. importance, no wonder Prague Castle has made it to the list of the UNESCO World Heritage Site.

If you haven't been to Prague, add this beautiful city to your travel bucket list and see it for yourself.

- | | | | | |
|---------------|-----------------|---------------|---------------|--------------|
| (A) leisurely | (B) appeal | (C) take in | (D) bursting | (E) enduring |
| (F) structure | (G) opportunity | (H) spring to | (I) residence | (J) historic |

四、篇章結構（占 8 分）

說明：第31.題至第34.題為單選題，每題 2 分。

第31.至34.題為題組

Sir Isaac Newton is widely known for his theory of universal gravity, but how did the scientist arrive at this revolutionary theory? Apart from the famous tale of an apple falling on his head, there is a lesser-known story about what led Newton to establish the law of gravitation.

It was 1678, and Newton had just suffered the first of his nervous breakdowns. For the following six years, the scientist locked himself away in his home. 31. It was during this period that Newton made groundbreaking discoveries, paving the way for his theory of universal gravity.

Newton's mental illness might have had an effect on his personality, turning him into a bitter and angry man. 32. Among his many disputes was one with the German philosopher Gottfried Wilhelm Leibniz. The two were in a battle over who had invented calculus, and toward the end of his life, Newton put an enormous amount of energy into discrediting Leibniz.

Back to Newton's self-isolation period. Up to that point, he had been a traditional 17th-century mechanistic scientist who saw the world as a bunch of billiard balls colliding. 33. But during his life of solitude, Newton studied alchemy and various sorts of papers on magic, and became fascinated with influence on objects without contact. In these books, the idea that substances had mysterious sympathies and antipathies toward one another was extensively explored. 34.

This unconventional idea might have inspired Newton to contemplate gravitation, allowing him to envision forces of attraction and repulsion that worked at a distance, a breakthrough that eventually led to his theory of universal gravity.

- (A) He frequently got himself into conflict with others, including some prominent figures of his time.
- (B) His self-imposed exile from British society was a critical turning point in the history of science.
- (C) There was no such concept as action at a distance, which was entirely absent from science then.
- (D) It suggested the existence of mystical forces that could affect an object even without touching it.

五、閱讀測驗（占 24 分）

說明：第35.題至第46.題為單選題，每題 2 分。

第35.至38.題為題組

In today's digital era, printing is considered essential to both individuals and businesses, but it demands heavy consumption of paper and ink, and has a significant environmental cost. So, how can we communicate our message on paper with minimal environmental impact? The answer may lie in our choice of fonts.

There are several factors that determine how much ink and paper a particular font consumes, including its weight, its style, its size, and its width and spacing. A lighter-weight font uses less ink than a heavier font. A font of the serif style generally uses more ink than that of the sans-serif style, for a serif font has little tails on the letters. A smaller or narrower font with less space between letters allows more text to fit on a page, reducing paper consumption. But no matter what font we choose, we must not compromise the legibility, and should ensure the text is easy to read.

Many regular fonts are not very ink-efficient or environmentally friendly because of the weight of the letters. Arial, compared with Times New Roman, performs poorly even though Times New Roman is a serif font. Arial also pales in comparison to Century Gothic, which uses about 30% less ink because of its fine print lines. However, Century Gothic is a large, broad and wide set font, so despite using less ink, it uses more paper.

Ryman Eco is designed to take advantage of how ink bleeds on paper. In this eco-font, each letter is composed of fine lines, so when printed at smaller sizes, these lines “bleed” to fill the gaps between them, resulting in the letters looking solid. At larger sizes, the lines become an interesting characteristic of the font, with the white space in each letter noticeable. Ryman Eco uses an average of 33% less ink than conventional fonts, without impacting legibility.

Can we potentially save the planet while engaging in the printing practice? Clearly, font selection plays a crucial role in making **that** possible. Besides choosing a more sustainable font, we can also print double-sided, and use recycled paper and ink cartridges. These small steps will make a huge difference.

35. According to the second paragraph, which of the following should be prioritized in selecting a font?
- (A) Whether it is not too heavy.
 - (B) Whether its style is sans-serif.
 - (C) Whether it is easily readable.
 - (D) Whether its spacing is not too wide.
36. Which of the following statements matches the results of comparing Arial, Times New Roman, and Century Gothic?
- (A) Arial is the least ink-efficient font of all.
 - (B) Times New Roman is the most readable on paper.
 - (C) Times New Roman uses more ink because it is a serif font.
 - (D) Century Gothic is the most paper-efficient despite its wide set.

37. Which of the following is printed in the Ryman Eco font?

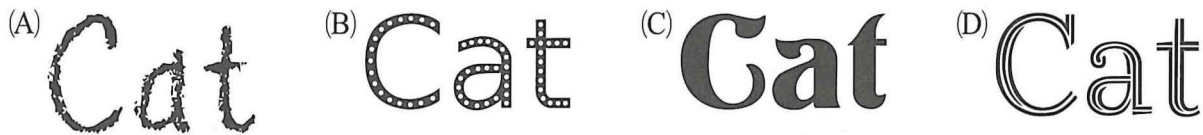

38. What does “that” in the last paragraph refer to?

- (A) Conducting printing without causing harm to the environment.
- (B) Designing appropriate fonts to meet the needs of different readers.
- (C) Using energy-efficient printing equipment to reduce carbon footprint.
- (D) Choosing eco-friendly fonts to save as much ink and paper as possible.

第39.至42.題為題組

Walruses and manatees are two large, gray, water-dwelling creatures. At first glance, they have a lot in common. Yet, they are not actually that much alike.

Walruses are bigger than manatees. The average manatee will weigh around 1,200 pounds, while walruses can weigh up to 3,700 pounds. The walrus is shorter than the manatee, but it has a lot more muscle and fat compared to the manatee.

Walruses live in some of the coldest places on the planet, whereas manatees tend to live in warm areas of the world. For example, walruses live on ice floes and on remote coastlines around the Arctic Circle and the sub-Arctic areas such as the U.S., Canada, Russia, and Greenland. They only live in saltwater areas of the world, though. Manatees live in both saltwater and freshwater areas, and they are also found in brackish environments. That means they are at home in rivers, ocean bays, and other such areas. However, one species of the manatee, known as the Amazonian Manatee, solely lives in the fresh water of the Amazon River.

Manatees are herbivores, thriving on sea grass, weeds, algae, and other plant life on the bottom of the sea. In contrast, walruses are entirely carnivores, feeding on a wide variety of foods, including shellfish, snails, fish, squid, and the occasional seal.

Manatees have about six teeth tucked away into their cheeks for eating, but walruses have 18 teeth, including the massive tusks for which they are well-known. The two most prominent teeth of walruses, their tusks, are massive canine teeth that grow up to 30 inches in length. These teeth have many uses for a walrus. They can be used to drag through the bottom sediments in water to find shellfish, to fend off predators or to attack large prey, like seals. To sum up, walruses’ teeth are more numerous and useful than those of manatees.

In conclusion, walruses and manatees do have some similarities, but their difference far outweighs their shared traits.

39. In what order does the author compare walruses and manatees in this passage?

- a. diet b. habitat c. dental structure d. size

- (A) d → b → a → c (B) a → d → b → c (C) b → c → a → d (D) c → a → b → d

40. According to the passage, where can manatees be found?

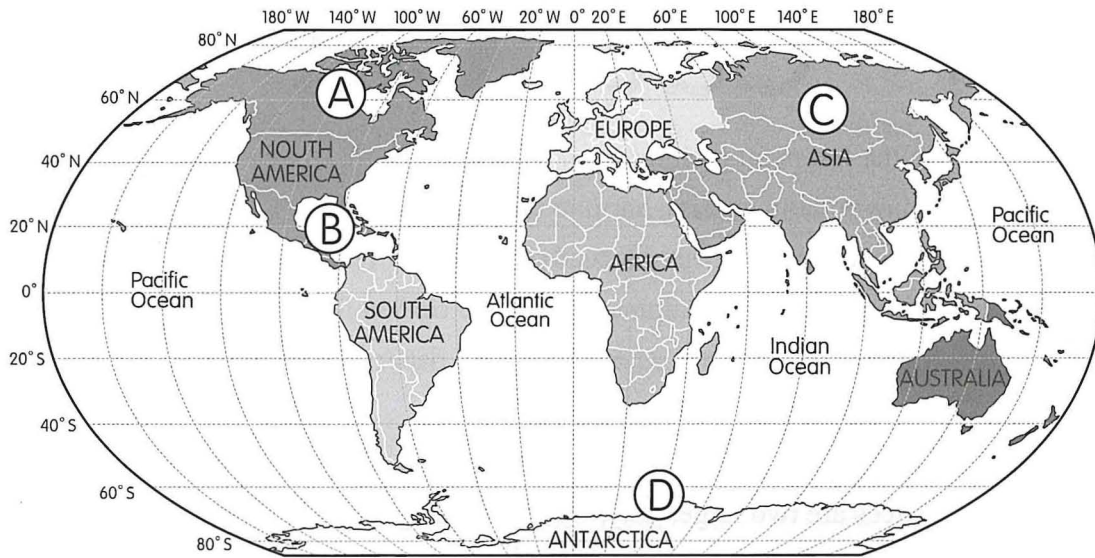

- (A) A (B) B (C) C (D) D
41. According to the passage, which of the following statements about walrus or manatees is true?
- (A) Manatees have massive canine teeth as long as 30 inches.
 - (B) Walrus can be over three times heavier than manatees.
 - (C) Manatees can live in all types of water areas regardless of their species.
 - (D) Walrus are strong predators despite having less muscle than manatees.
42. A student is designing a poster for the passage. Which of the following templates is most suitable for the content?

(A) A SWOT analysis.

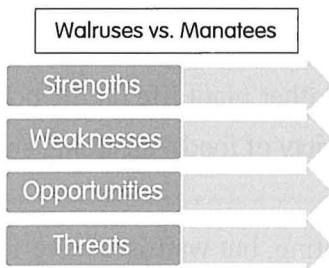

(B) A life cycle chart.

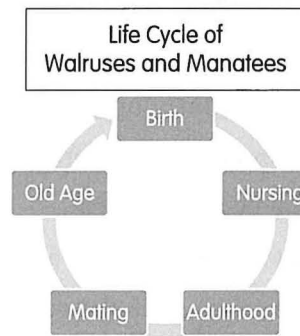

(C) A pyramid chart.

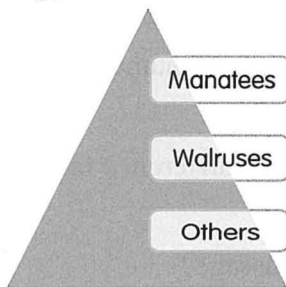

(D) A Venn Diagram.

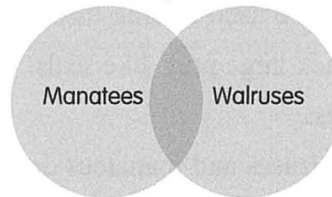

第43.至46.題為題組

The Flower of Life is one of the most ancient symbols known to humanity. It is a geometric figure composed of multiple evenly-spaced, overlapping circles that are arranged so that they form a flower-like pattern with the center of each circle on the circumference of six surrounding circles of the same diameter. The Flower of Life can be found in temples, art and manuscripts worldwide, and has held profound meanings for many cultures throughout history. It is one prime example of what is known as sacred geometry.

Sacred geometry is a way of thinking based on pattern recognition; it observes the fundamental relationship of space, time and shape or form. This philosophy gives symbolic meanings to the basic patterns of existence, and by studying the nature of these cosmic patterns and their relationships, we can develop a deeper understanding of the essential rules that govern the universe.

The term “sacred geometry” also refers to geometry employed in the design of holy architecture and sacred art. This type of geometry is used to create works for religious purposes because mathematical ratios, harmonics and proportionality also shape music, light and life itself. Sacred geometry is the foundation of the construction of various sacred structures, ranging from altars in homes to large and elaborate buildings such as temples, mosques, and churches. The use of the divine mathematics is also present in the design of natural sacred places like sacred groves and holy wells, as well as the creation of religious art and iconography. Even non-permanent works of art like sand-paintings follow the principles of this geometric approach.

In essence, sacred geometry attributes a religious or cultural value to many of its fundamental forms of space and time. According to this belief system, the basic patterns of existence are perceived as sacred because in contemplating them we are contemplating the origin of all things. By discovering the nature of these forms and their relationship to each other, we can gain insight into the scientific, philosophical, psychological, aesthetic and mystical laws of the universe.

43. Why is the Flower of Life mentioned in this passage?
- (A) To show what symbolic meaning it may have.
 - (B) To explain how it inspires us to appreciate art.
 - (C) To demonstrate what sacred geometry can be like.
 - (D) To indicate where sacred geometry is commonly seen.
44. According to the passage, which of the following is **NOT** mentioned as an example of the practice of sacred geometry?
- (A) Designing places of worship or holy sites.
 - (B) Creating works of art for temporary display.
 - (C) Understanding the rules that govern the natural world.
 - (D) Identifying various features of different communities.
45. How does the author conclude this essay?
- (A) By restating the main points.
 - (B) By offering a prediction.
 - (C) By making a recommendation.
 - (D) By teaching a moral lesson.
46. Which of the following words are used in the passage to refer to sacred geometry?
- a. mathematics b. origin c. belief system d. philosophy e. manuscripts
- (A) b, d, e
 - (B) a, b, d
 - (C) a, c, d
 - (D) a, c, e

第貳部分、混合題（占 10 分）

說明：本部分共有 1 題組，每一子題配分標於題末。限在答題卷標示題號的作答區內作答，並以規定用筆作答。

第47.至50.題為題組

World War II was a global conflict that affected millions of lives and forever changed the course of history. With countless stories to draw on, filmmakers have crafted many thought-provoking movies that explore the depths of this historical event. Here are three brief introductions, each offering a glimpse into a movie set in WWII.

Studio Ghibli, the film company behind animated classics like *Castle in the Sky* and *Nausicaä of the Valley of the Wind*, is known for its mystical creatures and fantastical worlds. But in 1988, the company's co-founder, Isao Takahata, cast aside the feel-good formula and directed *Grave of the Fireflies*, a heart-wrenching tale of two siblings trying to survive in Japan as World War II drew to a close. While many animated movies for children tend to be shallow and lack meaningful content, *Grave of the Fireflies* remains one of the most visually stunning and emotionally moving genre films of all time. It has won numerous awards both at home and abroad.

Known for his blockbusters *E.T. the Extra-Terrestrial*, *Jaws*, and *Jurassic Park*, Steven Spielberg surprised the viewers with one of the most intimate and affecting onscreen portrayals of the Holocaust: *Schindler's List*. Liam Neeson stars as Oskar Schindler, a German industrialist who operates under the radar to save his Jewish workers from the mass killing by the Nazis. The film reminds us to remain hopeful in one of the darkest corners of human history, paying tribute to the millions who lost their lives and to those who survived. Winning seven Academy Awards including Best Picture, *Schindler's List* is a movie that everyone should experience at least once.

It's definitely a bold choice for a director to portray Adolf Hitler as a playful imaginary friend to a 10-year-old Nazi boy, but Taika Waititi managed to pull it off, which marked a significant turning point in his professional journey. *Jojo Rabbit* follows the story of a young boy called Jojo, a devoted Hitler Youth member who finds out his less-than-ardent mother is hiding a Jewish girl in their walls. Putting children at the forefront of a world undergoing dramatic change, the movie is both hopeful and deeply tragic. With vibrant colors, complex characters, and an upbeat soundtrack, this Oscar-winning movie is an endlessly entertaining satire that one will enjoy with every watch.

47. -48. 請從本文選出兩個單詞（word）填入下列兩個空格，並視語法需要作適當的字形變化，使句子語意完整、語法正確，且符合全文文意。（填充，每格 2 分）

Some war movies, like *Grave of the Fireflies*, depict the hardship of struggling for 47. in wartime, while others, such as *Schindler's List*, convey the message of 48., reminding viewers that light exists even in the darkest history of humanity.

49. Which **phrase** in the description of *Schindler's List* means “unnoticed by the authorities?”（簡答，2 分）

50. From (A) to (F), which descriptions fit all three movies? (多選題, 4 分。)

- (A) All gained significant recognition.
- (B) All are targeted at a young audience.
- (C) All are funny but have deep meanings.
- (D) All are set at the beginning of World War II.
- (E) All explore the theme of racial oppression.
- (F) All three directors made their own career breakthrough.

第參部分、非選擇題 (占 28 分)

說明：本部分共有二大題，請依各題指示作答，答案必須寫在「答題卷」標示題號之作答區內，作答時不必抄題。

一、中譯英 (占 8 分)

說明：依題號將以下中文句子譯成正確、通順、達意的英文。每題 4 分，共 8 分。

1. 當地居民不被允許靠近那棟有倒塌風險的舊大樓。
2. 市長已經宣布直到問題解決之後，這項禁令才會廢除。

二、英文作文 (占 20 分)

說明：依提示寫一篇英文作文。文長至少 120 個單詞 (words)。

提示：網路上一篇關於「參加喜宴或是聚餐，大家比較喜歡的是流水席還是飯店正式宴會」的貼文，引發網友熱烈的討論。不同的餐敘，不僅用餐方式不同，整體氣氛也不同。請以「聚會用餐」為主題，並依據下列兩張圖片的內容，寫一篇英文作文，文分兩段。第一段描述圖 A (a 10-course banquet) 和圖 B (an all-you-can-eat buffet) 的兩種用餐方式各有什麼特色。第二段則說明與朋友聚餐時，這兩種用餐方式當中，你比較喜歡哪一種，並解釋你的理由。

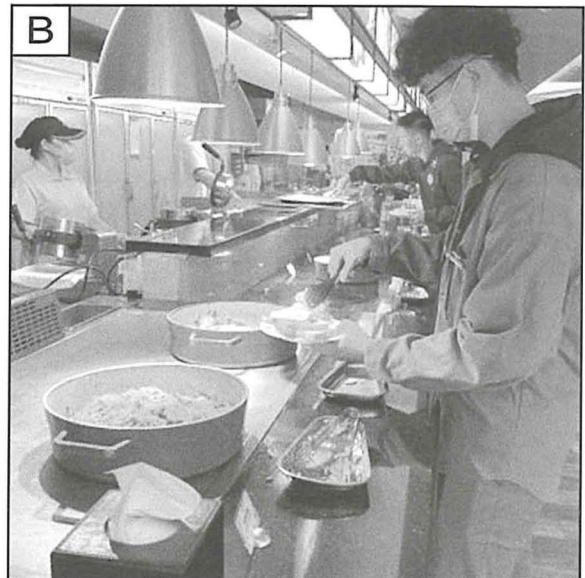

1

臺北區 112 學年度第一學期

學科能力測驗模擬考試

英文考科參考答案暨詳解



99363113-32

版權所有·翻印必究

英文考科詳解

1.	2.	3.	4.	5.	6.	7.	8.	9.	10.
(A)	(D)	(B)	(C)	(B)	(C)	(A)	(A)	(D)	(B)
11.	12.	13.	14.	15.	16.	17.	18.	19.	20.
(C)	(B)	(C)	(A)	(D)	(B)	(A)	(D)	(C)	(B)
21.	22.	23.	24.	25.	26.	27.	28.	29.	30.
(D)	(B)	(H)	(E)	(G)	(A)	(C)	(F)	(I)	(J)
31.	32.	33.	34.	35.	36.	37.	38.	39.	40.
(B)	(A)	(C)	(D)	(C)	(A)	(D)	(A)	(A)	(B)
41.	42.	43.	44.	45.	46.	47.	48.	49.	50.
(B)	(D)	(C)	(D)	(A)	(C)	見詳解	見詳解	見詳解	(A)(F)

第壹部分、選擇題

一、詞彙題

目標：評量考生對高中常用實詞詞彙 (content words) 的構詞、語意、字詞搭配 (collocation) 的理解與運用能力。

- (A) 難易度：中偏難
解析：考動詞。建築公司必須向市議會提交建築計畫以取得同意。
(A)提交 (B)保護 (C)掌舵 (D)維持
- (D) 難易度：中偏易
解析：考形容詞。充足的證據顯示這個男人有罪，他最終被逮捕並送入監獄。
(A)微妙的 (B)空洞的 (C)機械的 (D)充足的
- (B) 難易度：中偏難
解析：考名詞。經理無法忍受工作場所的不當行為，並要求員工要為自己的行為負責。
(A)猶豫 (B)忍耐 (C)合作 (D)區別
- (C) 難易度：中偏易
解析：考副詞。火車毫無預警地突然停下，讓好幾個乘客從座椅上摔下來。
(A)最初地 (B)有意識地 (C)突然地 (D)精確地
- (B) 難易度：難
解析：考動詞。沒有國家能接受其他國家試圖干涉其內政並操控選舉。
(A)修改 (B)干涉 (C)努力 (D)相似
- (C) 難易度：中偏難
解析：考形容詞。我們應該避免在昏暗的光線下玩手機太久，那樣會導致不可逆轉的永久性傷害。
(A)有效率的 (B)輕率的 (C)永久的 (D)義務的
- (A) 難易度：中偏難
解析：考名詞。Jacob 對於乾淨有難以控制的執著，無法忍受任何人把房子弄亂。
(A)執念 (B)災難 (C)肥料 (D)大會
- (A) 難易度：中偏難
解析：考動詞。這家公司被指控歧視一位女性員工，她和同樣工作的男同事所領到的薪資是不平等的。
(A)歧視 (B)參加...運動 (C)協商 (D)禁止
- (D) 難易度：中偏易
解析：考副詞。這個機構是專門以慈善目的而運作，其所有努力都是為了幫助有需要的人。
(A)可能地 (B)迅速地 (C)憤怒地 (D)專門地
- (B) 難易度：難
解析：考名詞。新冠肺炎疫情期間，人們被要求遵守必要的抗病毒預防措施來保持安全並防止其傳播。
(A)流通 (B)預防措施 (C)義務 (D)承諾

二、綜合測驗

第11.至15.題為題組

在知名的西部低地大猩猩 Koko 大約十二個月大的時候，動物心理學家 Francine Patterson 嘗試訓練她用手語溝通。根據 Koko 指導者的說法，她在四十六歲離世之前，已經學會了數量驚人的詞彙。Patterson 與她的團隊紀錄下 Koko 能運用大約兩千字來傳達思想與情感。然而，有些科學家質疑 Patterson 的方法。他們也

爭論 Koko 所傳達的訊息中有多少真正是來自於她本身，而且其中又有多少是人類把自己的想法和感情投射到她身上所詮釋出來的。

其中一個抱持懷疑的科學家是赫瑞瓦特大學的 Graham Turner 教授。他坦言，用心教導人猿比手語的努力開始於一九六零年代，而且因為學者們致力於教導源自於美式手語的一些個別手勢，有些人猿真的學會了一些語言技能。然而，考量到美式手語系統的複雜度，Turner 申論，如果因此暗示 Koko 或其他人猿像人類一樣真正地學會了運用手語的能力，那就是一種曲解了。

不論 Koko 是否真的能運用手語，以一隻大猩猩來說，她對手勢的運用能力的確是非常傑出。Koko 的故事將持續啟發許多領域的研究者。

目標：評量考生參酌上下文意發展，掌握各類詞彙 (含實詞、虛詞、慣用語及轉折詞等) 及語法應用的能力。

內容：本篇文章主談不同專家對於猩猩掌握人類手語的看法。

- (C) 難易度：中偏易
解析：(A)相似地 (B)此外 (C)然而 (D)因此
此格考句子連結，因為後句提出與前句相反的論點，語氣有轉折，故選(C)。
- (B) 難易度：中
解析：(A)轉移 (B)投射 (C)沉思 (D)指出
根據上下文，學者懷疑人類研究者將自己的想法或感受投射到 Koko 身上，同時可與 onto 搭配的動詞為 project，故選(B)。projecting 在此是由 who projected 改寫而來的分詞片語。
- (C) 難易度：中偏易
解析：(A)嘗試 (原形) (B)嘗試 (過去式；過去分詞) (C)嘗試 (現在分詞) (D)嘗試 (不定詞)
此格考 with+O+Ving / Ven 的補述用法，研究者是主動嘗試教人猿手語，故選(C)。
- (A) 難易度：中
解析：(A)真正地 (B)激進地 (C)更可取地 (D)不可避免地
此格根據 Turner 語意，大猩猩 Koko 或其他人猿並不能像人類一樣真正地學會手語。
- (D) 難易度：中偏難
解析：(A)只要 (B)縱然 (C)要是 (D)不論
根據前文，學者對於 Koko 是否能正確使用手語仍有爭議，但其使用手勢的能力以人猿來說仍是傑出的，故根據句意選擇(D)。

重要字、詞與片語

debate v. 爭論	interpret v. 詮釋	skeptical adj. 懷疑的
derived adj. 源自於	complexity n. 複雜度	
supposed adj. 所謂的	command n. 運用能力	

第16.至20.題為題組

在社會心理學中，「內團體」指的是一個人所屬的團體，而「外團體」則是一個人不屬於的團體。在態度與人格特質上，人們傾向看待他們內團體的成員彼此不同，而認為外團體的成員彼此相似。這種現象影響了人們對外團體個別成員認知，被稱為「外團體同質性效應」。

研究發現，各式各樣的因素造成了「外團體同質性效應」。一個明顯的事實是，人們常常跟內團體的成員接觸，增加了他們對內團體成員差異性的理解。他們往往以個人的獨特性而非概括性的特質來整理或回想內團體的資訊。再者，人們比較有動力去區分內團體當中他們未來會接觸到的成員。然而這種動機卻很少延伸到外團體成員的身上。當這些因素一起作用，結果通常是一個有著形形色色個體的內團體，與一個其中成員顯得相像的外團體。

因為這樣的偏見可能造成人們對外團體有錯誤的論斷，所以對我們而言很重要，努力去更了解不同團體的人並且更接納他們。

內容：本篇文章主談心理學的「外團體同質效應」及其影響。

- (B) 難易度：中
解析：(A)討人喜歡的 (B)相似的 (C)優越的 (D)慷慨的
根據上下文文意，一般人傾向將外團體的人同質化，故選(B)。

17. (A) 難易度：中
 解析：(A)導致 (B)從事 (C)依靠 (D)源自
 各種因素合力造成了「外團體同質性效應」，根據文意選(A)。
18. (D) 難易度：難
 解析：(A)伴隨著 (B)根據 (C)不論 (D)而非
 此格考片語，依據文意，整理、回想內團體成員資訊的依據是前者(個人的獨特性)，而非後者(概括性的特質)，故選(D)。
19. (C) 難易度：易
 解析：(A)也不 (B)反之 (C)然而 (D)同理
 此格依上下文意，理解內團體個別成員的動力無法延伸至外團體，語氣有轉折，故選(C)。
20. (B) 難易度：中偏易
 解析：此題考關係副詞，先行詞 *outgroup* 被視為一地點，裡頭的成員看來相似，*where = in which*，故選擇(B)。

重要字、詞與片語

<i>homogeneity n.</i> 同質性	<i>perception n.</i> 看法
<i>distinction n.</i> 區分	<i>assortment n.</i> 各式各樣
<i>bias n.</i> 偏見	<i>assumption n.</i> 推論；臆測

三、文意選填

第21.至30.題為題組

捷克首都布拉格是歐洲最美妙的城市之一。這座城市充滿特色，而這點可以從它特別的舊城區到獨有的老式電影院看出。這迷人城市的巨大的吸引力引來世界各國的旅客，使它成為全球最受歡迎的景點之一。

有著十六個橋墩，橫跨著整條莫爾道河，查理大橋是任何計畫來布拉格的旅客都會立刻想到的。過去，這經典的大橋連接布拉格的舊城與布拉格城堡，這使得它對這城市的文化景色有莫大又歷久不衰的影響。從遠方欣賞，能見整座查理大橋的雄偉壯麗，旅客有機會以相機或手機捕捉大橋的美。然而，探索查理大橋最棒的方式還是在橋上用慢而悠閒的速度散步。橋上兩側各有一排雕像，一共三十座。當遊客在橋上散步，他們能欣賞這些精緻藝術作品的細節。每一尊雕像都是視覺饗宴。

另一個必去的觀光景點是布拉格城堡，它是世界上最大的城堡。它是一個城堡建築群，有著大量令人敬畏的建築，包含聖維特大教堂。這個神聖的建築是布拉格城堡的主要特色，以它的哥德式建築結構吸引目光。它建立於 880 年，提供波西米亞國王權力寶座，而布拉格城堡至今仍然是捷克總統官邸。富含建築價值及歷史重要性，布拉格城堡被列在聯合國世界文化遺產中。

若你沒有去過布拉格，把這座優美的城市加入你的旅行清單，親自去看看吧！

目標：評量考生依據篇章文意發展，掌握實詞詞彙(含慣用語及轉折詞)運用的能力。

內容：本文談捷克布拉格景點介紹。

21. (D) 難易度：中偏難
 解析：*burst with* 作片語動詞，表「充滿…」，句意為「這座城市充滿特色，而這點可以從它特別的舊城區到獨有的老式電影院看出」。故選(D)。
22. (B) 難易度：中
 解析：此題應填入名詞。*appeal* 表「吸引力」，句意為「這迷人城市的巨大的吸引力引來世界各國的旅客，使它成為全球最受歡迎的景點之一」。故選(B)。
23. (H) 難易度：中
 解析：此題應填入動詞或片語動詞。片語動詞 *spring to* 表「躍入」，搭配名詞 *spring to mind* 表「躍入腦海」，句意為「任何計畫來布拉格的旅客都會立刻想到查理大橋」故選(H)。
24. (E) 難易度：中
 解析：此題應填入形容詞，*enduring* 表「歷久不衰的」，句意為「過去，這經典的大橋連接布拉格的舊城與布拉格城堡，這使得它對這城市的文化景色有莫大又歷久不衰的影響」。故選(E)。

25. (G) 難易度：中偏易
 解析：此題應填入名詞，*opportunity* 表「機會」，句意為「旅客有機會以相機或手機捕捉大橋的美」。故選(G)。
26. (A) 難易度：中
 解析：此題應填入形容詞，*leisurely* 表「悠閒的」，句意為「然而，探索查理大橋最棒的方式還是在橋上用慢而悠閒的速度散步」。故選(A)。
27. (C) 難易度：中
 解析：此題應填入動詞或片語動詞，*take in* 表「吸收，欣賞」，句意為「當遊客在橋上散步，他們能欣賞這些精緻藝術作品的細節」。故選(C)。
28. (F) 難易度：中
 解析：此題應填入名詞，*structure* 表「大型建築」，句意為「這個神聖的建築是布拉格城堡的主要特色，以它的哥德式建築結構吸引目光」。故選(F)。
29. (I) 難易度：中
 解析：此題應填入名詞，由前文可知布拉格城堡曾為波西米亞國王住所，而 *official residence* 表「官邸」，放入句子意思為「它建立於 880 年，提供波西米亞國王權力寶座，而布拉格城堡至今仍然是捷克總統官邸」。故選(I)。
30. (J) 難易度：中偏易
 解析：此題應填入形容詞，*historic* 表「歷史上著名、重要的」，句意為「富含建築價值及歷史重要性，布拉格城堡被列在聯合國世界文化遺產中」，故選(J)。

重要字、詞與片語

<i>backstreets n.</i> 舊區，貧民區
<i>pillar n.</i> 柱子，橋墩
<i>Gothic adj.</i> 哥德式的

四、篇章結構

第31.至34.題為題組

牛頓的萬有引力理論廣泛為人知曉，但這位科學家是如何達成這個革命性的理論呢？除了蘋果掉到他頭上這個知名的故事外，還有一個比較不為人知的故事，也與牛頓如何建立引力法則有關。

在西元 1678 年，牛頓剛剛遭逢了人生數次精神崩潰中的第一次崩潰。接著的六年，這位科學家把自己關在家裡。**31. (B)牛頓自我放逐於英國社會之外的舉動是科學史上的一個關鍵轉捩點。**就是在這個時期，牛頓有了突破性的發現，也為他的萬有引力理論鋪路。

牛頓的精神疾病可能對他的個性造成影響，他變成一個易怒、憤恨不平的人。**32. (A)他常常跟別人起衝突，還包括當時一些顯赫的人物。**其中一場爭執是跟德國哲學家萊布尼茲發生的。兩者爭論是誰發明了微積分，而且牛頓直至死前，還是卯足全力來批評萊布尼茲。

回到牛頓自我隔離的時期吧。直到那個時候，他一直是傳統 17 世紀的機械論科學家，他把世界看成一些撞球互相撞擊。**33. (C)那時沒有「超距作用」的概念，這是在當時科學上找不到的概念。**但是在他的獨居時期，牛頓研讀煉金術和各式關於巫術的論文，而且對於物體之間未經碰觸就能產生影響的現象感到著迷。在這些書籍中，物體之間彼此可以神祕相吸和相斥的想法被廣泛探討。**34. (D)這個想法暗示神奇力量的存在，它們能夠不碰觸物體就影響物體。**

這個創新的想法可能啟發牛頓去思索引力，讓他看見力量在距離之間的相吸相斥，這個突破最終使得萬有引力理論得以發生。
 目標：評量考生掌握篇章的組織架構與理解文意脈絡的能力。
 內容：本文介紹牛頓萬有引力理論及其個人軼事。

難易度：中偏難

重要字、詞與片語

<i>universal gravity n.</i> 萬有引力	<i>breakdown n.</i> 崩潰
<i>self-imposed exile n.</i> 自我放逐	<i>conflict n.</i> 衝突
<i>prominent adj.</i> 顯著的	<i>dispute n.</i> 爭論
<i>discredit v.</i> 抹黑	<i>mechanistic adj.</i> 機械論的
<i>billiard balls n.</i> 撞球	<i>action at a distance n.</i> 超距作用
<i>sympathy n.</i> 吸引	<i>antipathy n.</i> 排斥
<i>repulsion n.</i> 排斥	

五、閱讀測驗

第35.至38.題為題組

在今天的數位時代，對個人和企業而言，列印都是必要之舉，但這需要大量消耗紙張和墨水，並且對環境造成重大影響。那麼，我們如何在紙上傳達訊息，同時將對環境的影響降至最低呢？答案可能在於我們對字體的選擇。

有幾個因素決定了特定字體消耗的墨水和紙張量，包括其字重、風格、大小，以及字寬和字距。較輕的字重比起較重的字重使用較少的墨水。襯線字體基本上也比非襯線字體耗墨量更大。字體較小或較窄，字母間的空隙少，可以讓更多的文字放在一頁上，從而減少紙張的消耗。但是，無論我們選擇哪種字體，我們都不能犧牲可讀性，應確保文字容易閱讀。

許多常規字體由於字母的字重而不太節省墨水。Arial 與 Times New Roman 相比表現不佳，儘管 Times New Roman 是襯線體。Arial 與 Century Gothic 相比也相形見绌，因為 Century Gothic 字體線條較細，使其使用的墨水少約 30%。然而，Century Gothic 字體設計較為寬大，所以儘管使用較少的墨水，它卻使用更多的紙張。

Ryman Eco 的設計是為了利用墨水在紙上滲透的特性。在這款環保字體中，每個字母都由細線組成，因此當以較小尺寸列印時，這些線條會「滲透」並填充它們之間的空隙，使字母看起來堅實。在較大的尺寸下，這些線條成為字體的有趣特徵，每個字母中的空白空間變得明顯。Ryman Eco 比常規字體平均少使用 33% 的墨水，而不影響可讀性。

我們是否可以在列印的同時挽救地球呢？很明顯，字體的選擇在實現這一目標上起著至關重要的作用。除了選擇對環境更永續的字體外，我們還可以雙面列印，並使用回收紙和墨水匣。這些小步驟可以帶來巨大的改變。

目標：評量考生綜合運用詞彙（含慣用語），掌握語意、語法、語用以及篇章結構的知識，理解文意脈絡、擷取文章重要訊息，並加以分析、比較與推理的能力。

內容：本文文章重點在介紹省墨的環保字體。

35. (C) 難易度：中

解析：根據第二段，選擇字體時，以下哪一項應該被優先考慮？

- (A) 字重是否太重。
- (B) 是否是無襯線的風格。
- (C) 是否易於閱讀。
- (D) 字距是否太寬。

36. (A) 難易度：中偏難

解析：以下哪一項陳述符合 Arial、Times New Roman 和 Century Gothic 之間的比較結果？

- (A) Arial 是這三個字體中最不省墨的。
- (B) Times New Roman 在紙上最易閱讀。
- (C) Times New Roman 因為是襯線字體，所以使用最多的墨水。
- (D) 儘管 Century Gothic 的字元寬，但它是省墨最省的。

37. (D) 難易度：中

解析：以下哪一項是用 Ryman Eco 字體列印的？因為本文提到「在這款環保字體中，每個字母都由細線組成，因此當以較小尺寸列印時，這些線條會「滲透」並填充它們之間的空隙，使字母看起來堅實。在較大的尺寸下，這些線條成為字體的有趣特徵，每個字母中的空白空間變得明顯。」，故選(D)。

38. (A) 難易度：中

解析：在最後一段中的「that」指的是什麼？

- (A) 印刷不會對環境造成傷害。
- (B) 設計適當的字體以滿足不同讀者的需求。
- (C) 使用節能列印設備以減少碳足跡。
- (D) 選擇環保字體以盡可能節省墨水和紙張。

重要字、詞與片語

digital era <i>n.</i> 數位時代	essential <i>adj.</i> 必要的、不可或缺的
environmental <i>adj.</i> 環境的	font <i>n.</i> 字體
weight <i>n.</i> 字重（在此指字體的粗細）	style <i>n.</i> 樣式
serif <i>n.</i> 襯線（字體特性，指字母末端的小橫線）	
sans-serif <i>adj.</i> 無襯線的	legibility <i>n.</i> 可讀性
ink-efficient <i>adj.</i> 省墨的	
bleed <i>v.</i> 滲透（在此指墨水在紙上的擴散）	
conventional <i>adj.</i> 普通的	sustainable <i>adj.</i> 可持續的
cartridge <i>n.</i> 墨水匣、墨盒	

第39.至42.題為題組

海象和海牛是兩種大型的灰色水棲生物。乍看之下，他們有很多共同點。然而，它們實際上並沒有那麼相似。

海象比海牛大。海牛的平均體重約為 1,200 磅，而海象的體重可達 3,700 磅。海象比海牛矮，但與海牛相比，它的肌肉和脂肪多得多。

海象生活在地球上一些最寒冷的地方，而海牛往往生活在世界上溫暖的地區。例如，海象生活在北極圈和美國、加拿大、俄羅斯和格陵蘭等亞北極地區的浮冰和偏遠海岸上。不過，它們只生活在世界上的鹹水地區。海牛生活在鹹水區和淡水區，它們也生活在半鹹水環境中。這意味著它們在河流、海灣和其他類似區域都很自在。然而，一種被稱為亞馬孫海牛的海牛只生活在亞馬孫河的淡水中。

海牛是食草動物，以海草、雜草、藻類和海底的其他植物為食。相比之下，海象完全是食肉動物，以多種食物為食，包括貝類、蝸牛、魚、魷魚，偶爾也會吃海豹。

海牛大約有 6 顆牙齒藏在臉頰裡用於進食，而海象有 18 顆牙齒，包括它們眾所周知的巨大象牙。海象的兩顆最突出的牙齒，即象牙，是巨大的犬齒，長達 30 英寸。這些牙齒對海象有很多用途。它們可用於拖過水中的底部沉積物以尋找貝類、抵禦捕食者或攻擊海豹等大型獵物。總而言之，海象的牙齒比海牛的牙齒更多，也更有用。

總之，海象和海牛確實有一些相似之處，但它们的差異遠遠超過它們的共同特徵。

內容：本文文章重點在比較海象與海牛相異之處。

39. (A) 難易度：中偏易

解析：作者以什麼順序比較海象和海牛？

- a. 飲食 b. 棲息地 c. 牙齒構造 d. 體型
- (A) d → b → a → c
- (B) d → a → b → c
- (C) a → c → b → d
- (D) c → a → b → d

40. (B) 難易度：中偏易

解析：根據本文，在下列何處可以找到海牛？

- (A) 北美洲極圈附近
- (B) 北回歸線附近海灣
- (C) 亞洲近北極區
- (D) 南極

41. (B) 難易度：中偏易

解析：根據文章，下列關於海象或海牛的陳述哪一個是正確的？

- (A) 海牛有長達 30 英寸的巨大犬齒。
- (B) 海象的體重是海牛的三倍多。
- (C) 海牛可以生活在所有類型的水域中，無論是何物種。
- (D) 海象是強壯的掠食者，儘管它們的肌肉比海牛少。

42. (D) 難易度：中偏易

解析：一名學生正在為該文章設計海報。以下哪個模板最適合其內容？

- (A) SWOT 分析表。
- (B) 生命週期表。
- (C) 金字塔圖。
- (D) 文氏關係圖。

重要字、詞與片語

walrus *n.* 海象 manatee *n.* 海牛
dwell *v.* 居住 floe *n.* 浮冰
the Arctic Circle *n.* 北極圈
herbivore *n.* 草食動物
carnivore *n.* 食肉動物
sediment *n.* 沉積物 fend off *phr.* 抵禦

第43.至46.題為題組

「生命之花」是人類已知的最古老的符號之一。它是由多個等距重疊的圓圈組成的幾何圖形，這些圓圈排列成花狀圖案，每個圓圈的中心位於六個直徑相同的周邊圓圈的圓周上。「生命之花」可以在世界各地的寺廟、藝術和手稿中找到，並且在整個人類歷史上對許多文化都具有深遠的意義。它是所謂的「神聖幾何」的最主要的例子之一。

「神聖幾何」是一種基於圖像識別的思維方式；它觀察空間、時間和形狀或形式之間的基本關係。這種哲學為存在的基本模式賦予象徵意義，通過研究這些宇宙模式的性質及其關係，我們可以更深入地了解支配宇宙運行的基本規則。

「神聖幾何」一詞也指用於設計神聖建築和神聖藝術的幾何學。這種類型的幾何被用於創作宗教作品，因為數學比率、諧波和比例也會塑造音樂、燈光和生活本身。「神聖幾何」是建造各種神聖結構的基礎，從住家的聖壇到大型精緻的建築，如寺廟、清真寺和教堂。神聖數學的使用也存在於自然聖地的設計中，如神聖樹林和聖井，以及宗教藝術和肖像畫的創作。甚至像沙畫這樣的非永久性藝術作品也遵循這種幾何方法的原則。

本質上，「神聖幾何」將宗教或文化價值賦予在許多基本的空間和時間形式上。根據這種信仰體系，存在的基本模式被認為是神聖的，因為在面對它們沉思或冥想時，我們也在思考萬物的起源。通過發現這些形式的本質及其相互關係，我們可以深入了解宇宙的科學、哲學、心理學、美學和神祕法則。

內容：本文文章重點在於「神聖幾何」被廣泛應用的面向。

43. (C) 難易度：中

解析：為什麼在這段文章中提到「生命之花」？

- (A) 為了顯示它象徵意義為何。
- (B) 為了解釋它如何啟發我們欣賞藝術。
- (C) 為了說明神聖幾何可以是什麼樣貌。
- (D) 為了指出神聖幾何可以在哪裡被看見。

44. (D) 難易度：中

解析：根據文章，以下哪一項不是神聖幾何應用的例子？

- (A) 設計敬拜場所或聖地。
- (B) 創作非永久展出的藝術作品。
- (C) 理解掌管自然世界的法則。
- (D) 辨識不同社群的諸般特色。

45. (A) 難易度：中

解析：作者如何總結這篇文章？

- (A) 重述要點。
- (B) 提供預測。
- (C) 做出建議。
- (D) 道德勸說。

46. (C) 難易度：中偏難

解析：文章中使用了哪些詞來指涉「神聖幾何」？

- a. 數學 b. 起源 c. 信仰系統 d. 哲學 e. 手稿
- (A) b, d, e (B) a, b, d (C) a, c, d (D) a, c, e

重要字、詞與片語

geometric *adj.* 幾何的 overlapping *adj.* 重疊的
circumference *n.* 圓周 diameter *n.* 直徑
manuscript *n.* 手稿 ratio *n.* 比例
harmonics *n.* (音樂)和諧音 proportionality *n.* 比例性
mosque *n.* (伊斯蘭教)清真寺 altar *n.* 祭壇
grove *n.* 樹叢, 樹林 iconography *n.* 圖像
sand-painting *n.* 沙畫 contemplate *vt.* 沉思
gain insight into sth. 獲得...的洞見 aesthetic *adj.* 美學的

第貳部分、混合題

第47.至50.題為題組

第二次世界大戰是一場全球性衝突，影響了數百萬人的生命，並永遠改變了歷史進程。以無數的故事作為借鑑，電影製作者製作了許多發人深省的電影來深入探索這個歷史事件。這裡有三個簡短的介紹，每個介紹都讓您得以一窺一部以二戰為背景電影。

吉卜力工作室是製作《天空之城》和《風之谷》等經典動畫的著名電影公司，以作品中的神祕生物和奇幻世界而聞名。但在1988年，公司聯合創始人高畑勳摒棄了那些令人感覺良好的公式，執導了《螢火蟲之墓》這個令人心碎、講述二戰即將結束時一對手足在日本努力生存的故事。雖然許多針對兒童拍攝的動畫電影容易流於淺薄而缺乏內涵，但《螢火蟲之墓》一直是有史以來最具視覺衝擊力和情感動人的類型電影之一，在日本及海外均獲多項大獎。

以《E.T. 外星人》、《大白鯊》和《侏羅紀公園》等賣座鉅片聞名的史蒂芬史匹柏，以《辛德勒的名單》這部電影讓觀眾為之震撼。這部電影是對大屠殺最私密也最有影響力的銀幕呈現之一，連恩尼遜飾演德國實業家奧斯卡辛德勒，他私下秘密拯救他的猶太工人免遭納粹大屠殺。這部電影提醒我們在人類歷史上最黑暗的角落裡仍要保持希望，並致敬數百萬失去生命者及倖存者。本片獲得包括最佳影片在內的七項奧斯卡獎，每個人都應該至少觀賞一次。

將阿道夫希特勒描繪成一個十歲納粹男孩想像中的調皮朋友，對導演來說絕對是一個大膽的選擇，但導演塔伊加維迪提辦到了，揭開了其職業生涯的重要轉捩點。《兔嘲男孩》以男孩喬喬的角度出發，喬喬是一個忠誠的希特勒青年團成員，他發現他那不太熱情的母親在牆裡藏了一個猶太女孩。這部電影將孩子放在正在經歷巨變的世界的第一線，充滿希望亦深具悲劇色彩。憑藉鮮豔的色彩、複雜的角色和歡快的配樂，這部獲得奧斯卡金像獎的電影是一部充滿娛樂性的諷刺作品，每次觀賞都會享受其中。

文章出處：<https://ew.com/movies/best-world-war-ii-movies/>

目標：評量考生綜合應用詞彙(含慣用語)，掌握語意、語法、語用以及篇章結構的知識，理解文章內容並擷取重要訊息加以分析、比較與推理，且能根據提示做出適當的表達或回應。
內容：關於三部描述第二次世界大戰的電影、導演的呈現方式及電影的獨特意義。

47. survival 或 surviving 48. hope 難易度：中偏難

解析：有些戰爭電影，像是《螢火蟲之墓》，描述戰時掙扎求生存的困難；而其他電影如《辛德勒的名單》則傳遞希望的訊息，提醒觀眾即使在人類最黑暗的歷史中，依然存在著光明。

評分原則：每題2分；大小寫、單複數、拼字錯誤均不給分。

49. under the radar 或 Under the radar. 難易度：中

解析：從《辛德勒的名單》的敘述中找出一個片語，意思是「未被當局察覺」。

評分原則：本題共2分，單複數、拼字錯誤均不給分。

50. (A)(F) 難易度：中偏難

解析：以下(A)到(F)選項中，哪些描述符合所有三部電影？

- (A) 都獲得顯著的認可。
- (B) 都針對年輕觀眾。
- (C) 都很有趣，但有很深的意涵。
- (D) 都設定在二戰開始時。
- (E) 都探討種族壓迫的主題。
- (F) 三個導演都創造出自己生涯上的突破。

評分原則：本題共4分，對一個答案得2分。若填寫超過兩個答案，本題以零分計算。

重要字、詞與片語

heart-wrenching *adj.* 令人心痛的 genre *n.* 類型、文體
blockbuster *n.* 賣座鉅片 industrialist *n.* 實業家
under the radar 低調神祕地 pay tribute to sb. 向某人致敬
portray *v.* 描寫 playful *adj.* 調皮的 imaginary *adj.* 想像的
put sth. off 成功完成某事 ardent *adj.* 熱情的
forefront *n.* 最前線 vibrant *adj.* 充滿活力的
upbeat *adj.* 歡樂的 soundtrack *n.* 配樂 satire *n.* 諷刺文

第參部分、非選擇題

一、中譯英

1. Local residents // are not allowed to // get close to the old building // (that is) at the risk of collapsing.
2. The mayor has announced (that) // the ban will not // be lifted until // the problem is solved.

評分原則

1. 本大題總分 8 分，每小題滿分 4 分。
2. 每個錯誤扣 0.5 分，各部分獨立，扣完為止。
3. 相同之拼字錯誤，只扣一次。
4. 句首未大寫或標點符號不妥，各扣 0.5 分，只扣一次。

二、英文作文

評分原則：本大題總分 20 分，採整體式評分，分為五等級：特優（19~20 分）、優（15~18 分）、可（10~14 分）、差（5~9 分）、劣（0~4 分），閱卷委員於閱讀完考生試卷後，初步決定一個分數，再以各分項評分標準（詳見下表）檢閱是否符合此分數。另外，字數明顯不足，扣 1 分。未分段，扣 1 分；寫多段，不扣分。

英文作文分項式評分指標

等級	優	可	差	劣
項目				
內容	主題（句）清楚切題，並有具體、完整的相關細節支持。（5~4 分）	主題不夠清楚或突顯，部分相關敘述發展不全。（3 分）	主題不明，大部分相關敘述發展不全或與主題無關。（2~1 分）	文不對題或沒寫（凡文不對題或沒寫者，其他各項均以零分計算）。（0 分）
組織	重點分明，有開頭、發展、結尾，前後連貫，轉承語使用得當。（5~4 分）	重點安排不妥，前後發展比例與轉承語使用欠妥。（3 分）	重點不明、前後不連貫。（2~1 分）	全文毫無組織或未按提示寫作。（0 分）
文法、句構	全文幾無文法、格式、標點錯誤，文句結構富變化。（5~4 分）	文法、格式、標點錯誤少，且未影響文意之表達。（3 分）	文法、格式、標點錯誤多，且明顯影響文意之表達。（2~1 分）	全文文法錯誤嚴重，導致文意不明。（0 分）
字彙、拼字	用字精確、得宜，且幾無拼字、大小寫錯誤。（5~4 分）	字詞單調、重複，用字偶有不當，少許拼字、大小寫錯誤，但不影響文意之表達。（3 分）	用字、拼字、大小寫錯誤多，明顯影響文意之表達。（2~1 分）	只寫出或抄襲與題意有關的零碎字詞。（0 分）